

O:\Division Information\Engineering Documents\Construction\COMMERCE CITY\CAD files\2016 Updated Files\307-01 (nu.307-09 (Roadway & Parking Typical Sections).dwg

NOTES:

1. AUXILIARY LANES SHALL BE 12' WIDE, INCLUDING GUTTER PANS
2. EASEMENTS MAY BE DEDICATED AS RIGHT-OF-WAY IF SETBACKS ARE NOT AN ISSUE
3. SIDEWALKS MAY MEANDER
4. DUAL LEFT TURNS SHALL BE PROVIDED WHERE TRAFFIC VOLUMES DICTATE
5. SEE PRINCIPAL & REGIONAL ARTERIAL INTERSECTION DETAILS FOR TURN LANE AND ROW CONFIGURATIONS.

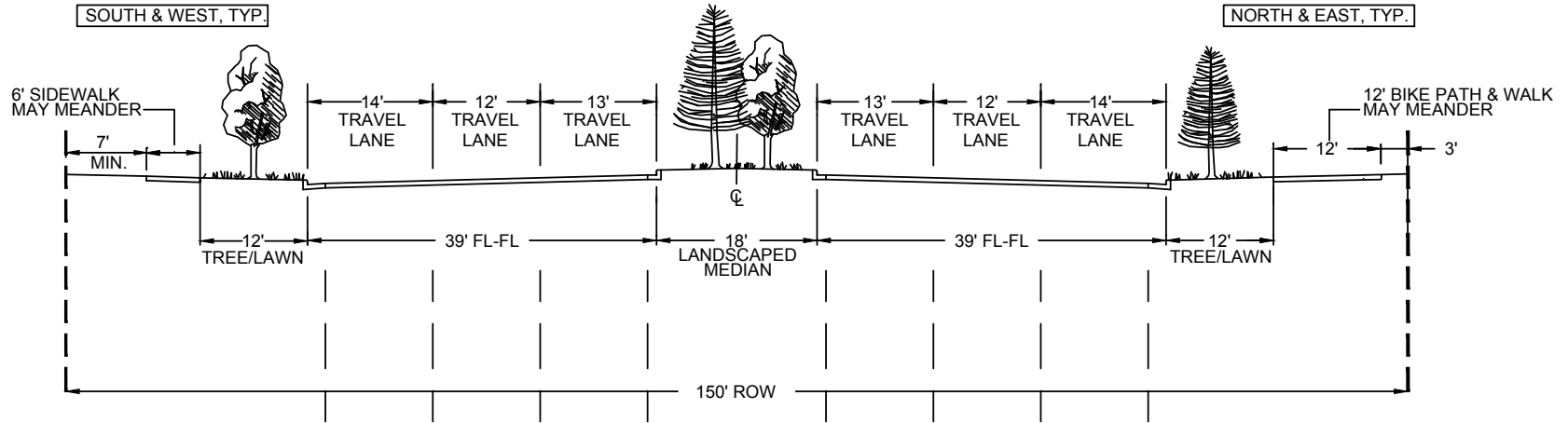

PRINCIPAL ARTERIAL
NOT TO SCALE

COMMERCE CITY
DEPARTMENT OF PUBLIC WORKS
ENGINEERING CONSTRUCTION STANDARDS

APPROVAL:

[Signature] 12-15-17
CITY ENGINEER DATE

ROADWAY AND PARKING DETAILS
TYPICAL STREET SECTIONS

DETAIL NO.
307-01



O:\Division Information\Engineering\Documents\Construction\COMMERCE CITY\CAD files\2016 Updated Files\307-01 Inu.307-09 (Roadway & Parking Typical Sections).dwg

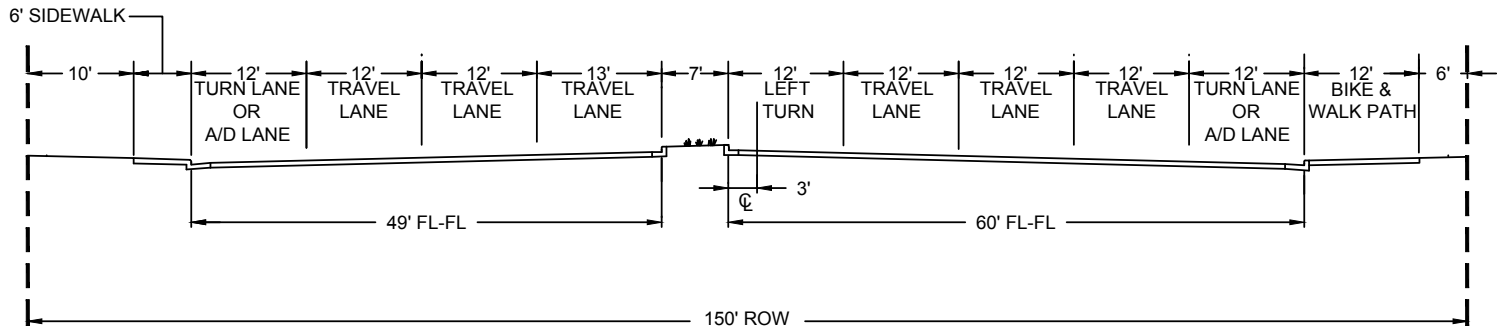

SINGLE LEFT TURN LANE

SOUTH & WEST, TYP.

NORTH & EAST, TYP.

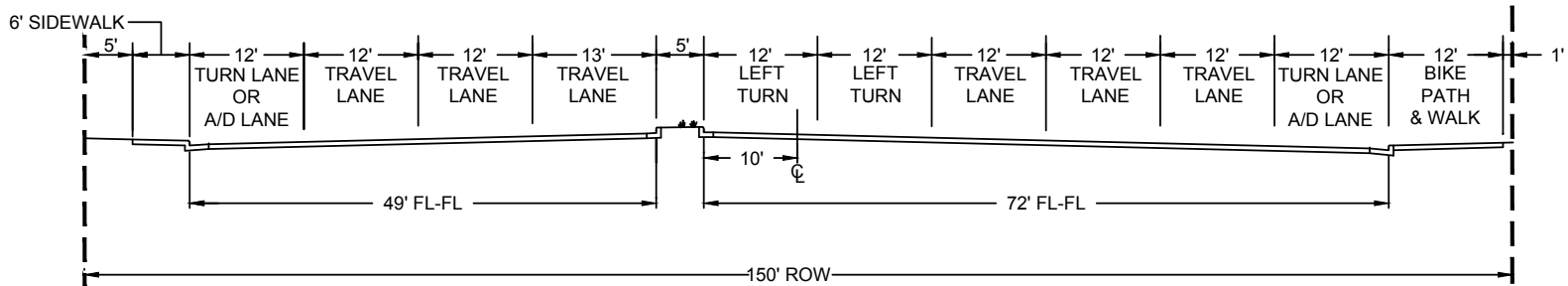

DUAL LEFT TURN LANES

**INTERSECTION DETAILS
PRINCIPAL ARTERIAL**

NOT TO SCALE

NOTES:

1. AUXILIARY LANES SHALL BE 12' WIDE, INCLUDING GUTTER PANS
2. EASEMENTS MAY BE DEDICATED AS RIGHT-OF-WAY IF SETBACKS ARE NOT AN ISSUE
3. SIDEWALKS MAY MEANDER

COMMERCE CITY
DEPARTMENT OF PUBLIC WORKS
ENGINEERING CONSTRUCTION STANDARDS

APPROVAL:

Andrew P. Kelly 12-15-17
CITY ENGINEER DATE

ROADWAY AND PARKING DETAILS
TYPICAL STREET SECTIONS

DETAIL NO.
307-02



NOTES:

1. AUXILIARY LANES SHALL BE 12' WIDE, INCLUDING GUTTER PANS
2. EASEMENTS MAY BE DEDICATED AS ROW IF SETBACKS ARE NOT AN ISSUE

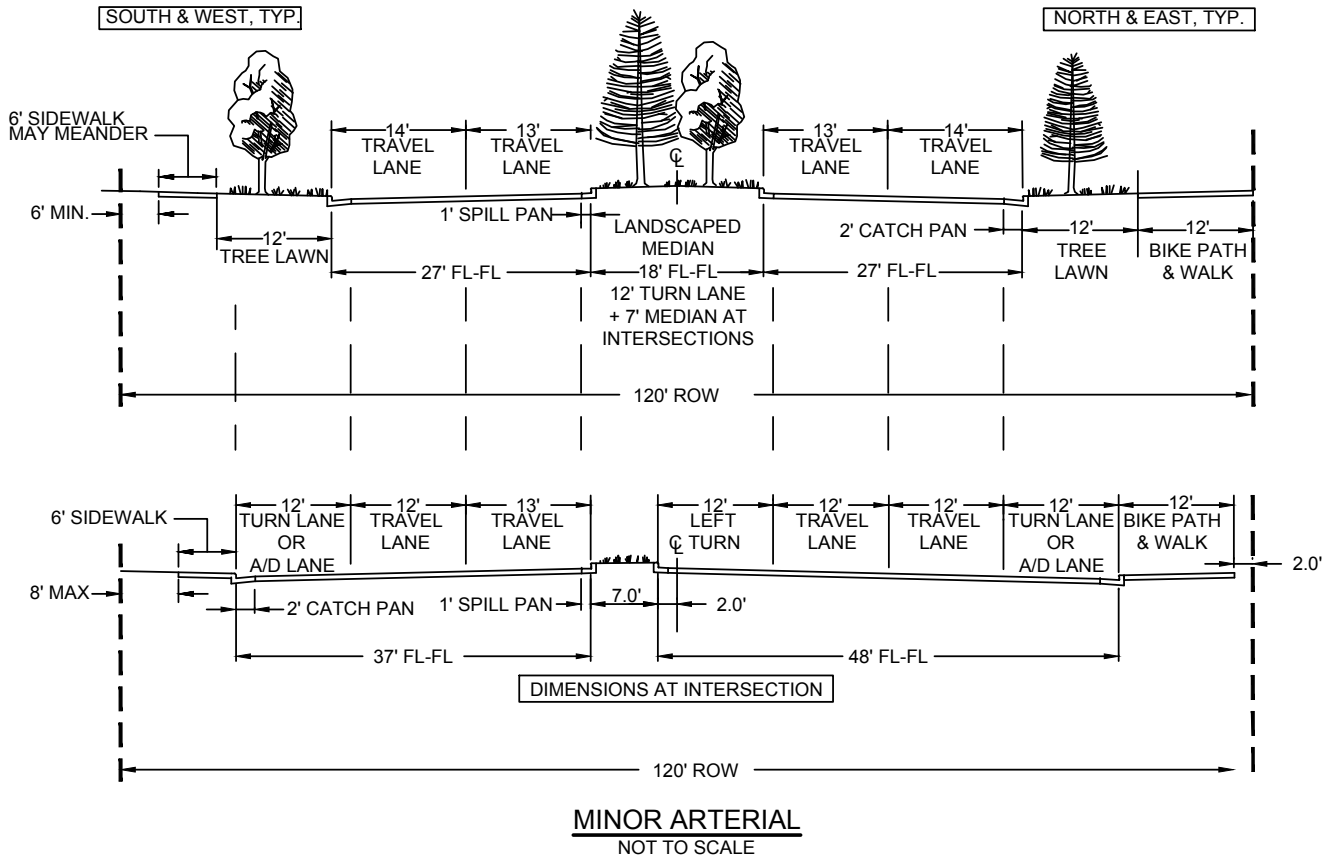

COMMERCE CITY
DEPARTMENT OF PUBLIC WORKS
ENGINEERING CONSTRUCTION STANDARDS

APPROVAL:

Andrew P. L... 12-15-17
CITY ENGINEER DATE

ROADWAY AND PARKING DETAILS
TYPICAL STREET SECTIONS

DETAIL NO.
307-03



O:\Division Information\Engineering Documents\Engineering and Construction\COMMERCE CITY\CAD files\2016 Updated Files\307-01 Inu.307-09 (Roadway & Parking Typical Sections).dwg

NOTES:

- 1. AUXILIARY LANES SHALL BE 12' WIDE, INCLUDING GUTTER PANS
- 2. EASEMENTS MAY BE DEDICATED AS ROW IF SETBACKS ARE NOT AN ISSUE
- 3. SIDEWALKS MAY MEANDER

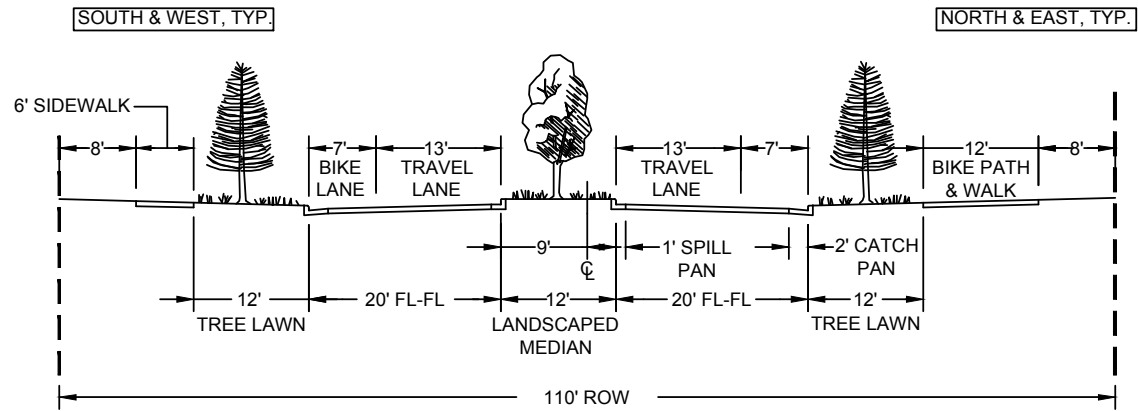

MULTIMODAL ARTERIAL
NOT TO SCALE

COMMERCE CITY
DEPARTMENT OF PUBLIC WORKS
ENGINEERING CONSTRUCTION STANDARDS

APPROVAL:

Andrew P. L... 12-15-17
CITY ENGINEER DATE

ROADWAY AND PARKING DETAILS
TYPICAL STREET SECTIONS

DETAIL NO.
307-04



C:\Division Information\Engineering Documents\Engineering and Construction\COMMERCE CITY\CAD files\2016 Updated Files\300-01 thru 300-07 (Roadway & Parking Typical Sections).dwg

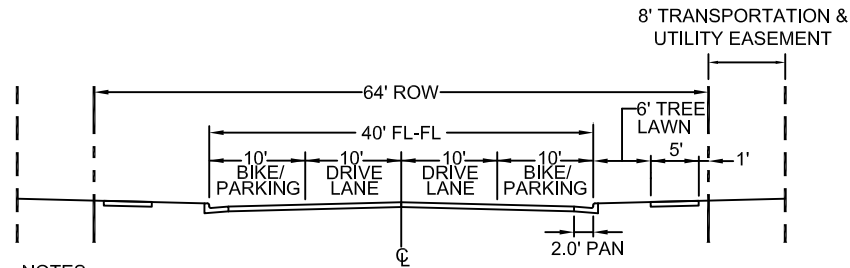

NOTES:

1. CENTER LINE STRIPE REQUIRED
2. THIS SECTION FOR STREETS WITH "BACK OUT" DRIVEWAYS IN RESIDENTIAL SUBDIVISIONS

MINOR COLLECTOR
NOT TO SCALE

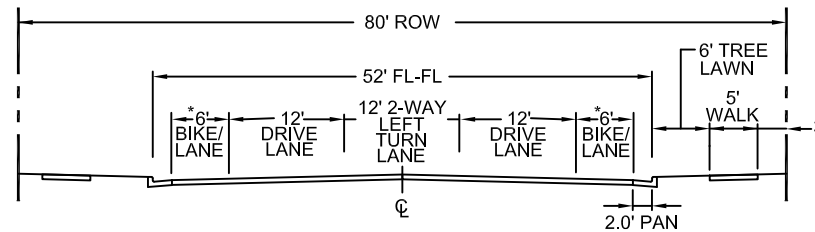

NOTES:

1. MAJOR COLLECTOR LANEAGE SHOWN
2. CITY ENGINEER TO DETERMINE STRIPING REQUIREMENTS FOR LOCAL INDUSTRIAL STREETS ON A CASE BY CASE BASIS
- *3. OMIT BIKE PATHS ON INDUSTRIAL STREETS (STILL 52' FL-FL)
4. NO ON STREET PARKING

MAJOR COLLECTOR / LOCAL INDUSTRIAL
NOT TO SCALE

COMMERCE CITY
DEPARTMENT OF PUBLIC WORKS
ENGINEERING CONSTRUCTION STANDARDS

**ROADWAY AND PARKING DETAILS
TYPICAL STREET SECTIONS**

APPROVAL:

Maria R. Fisher

05-27-16

CITY ENGINEER

DATE

DETAIL NO.

307-05



S:\Trainproj\100049520 - Commerce City Engineering Standards\DesignDrawings\Reference_Files\CCC DWG\300-01 thru 300-07 (Roadway & Parking Typical Sections).dwg

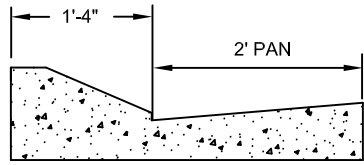

MOUNTABLE CURB DETAIL

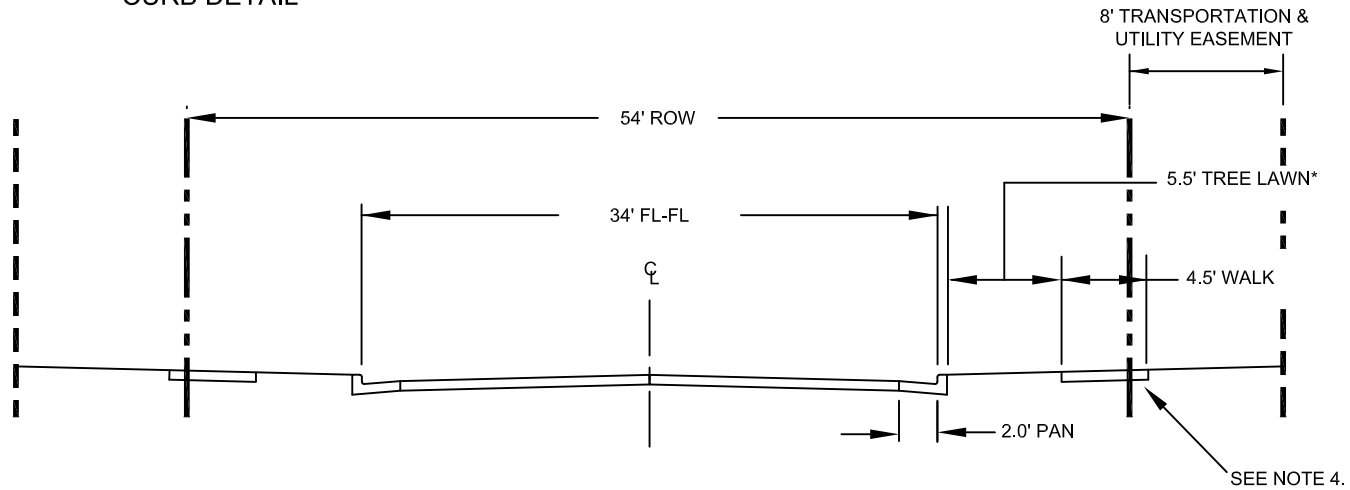

NOTE:

- 1. STRIPING NOT REQUIRED
- 2. ON STREET PARKING ALLOWED
- *3. IRRIGATED & UNIFORMLY LANDSCAPED TREE LAWN TO BE INSTALLED BY DEVELOPER
- 4. IF MOUNTABLE CURB IS USED, SIDEWALK WILL ENCROACH 1'-4" INTO TRANSPORTATION EASEMENT

LOCAL RESIDENTIAL WITH DETACHED WALKS (NO ALLEY)

NOT TO SCALE

COMMERCE CITY
DEPARTMENT OF PUBLIC WORKS
ENGINEERING CONSTRUCTION STANDARDS

APPROVAL:

Maria A. Fisher

05-27-16

CITY ENGINEER

DATE

ROADWAY AND PARKING DETAILS
TYPICAL STREET SECTIONS

DETAIL NO.

307-06



S:\Training\100049520 - Commerce City Engineering Standards\Design\Drawings\Reference_Files\CCC DWGs\300-01 thru 300-07 (Roadway & Parking Typical Sections).dwg

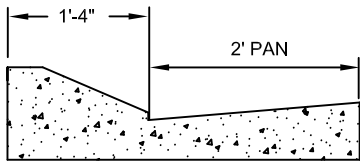

MOUNTABLE CURB DETAIL

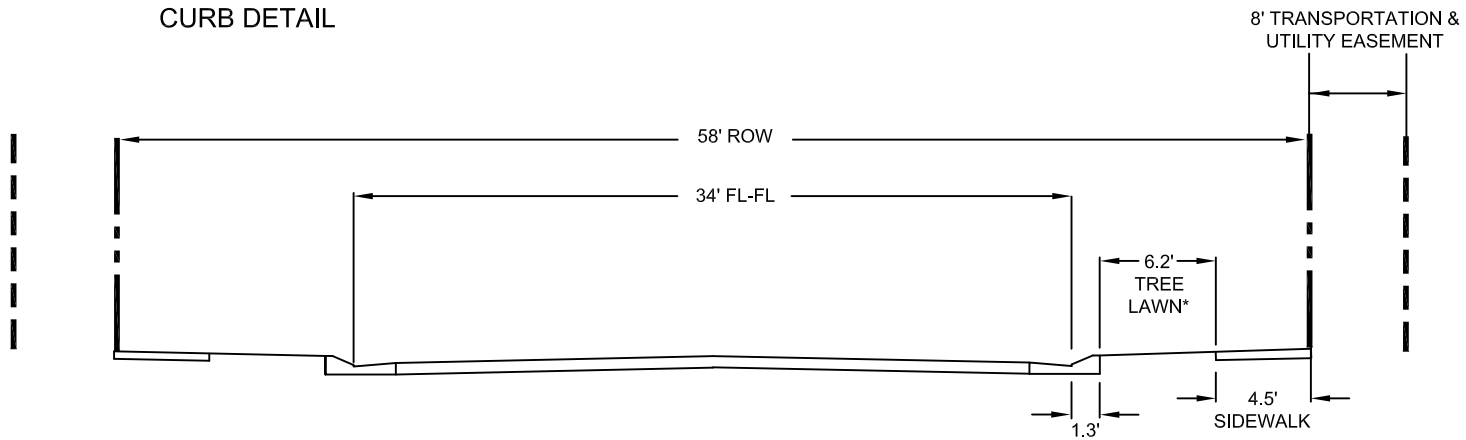

NOTE:

- 1. STRIPING NOT REQUIRED
- 2. ON STREET PARKING ALLOWED
- *3. IRRIGATED & UNIFORMLY LANDSCAPED TREE LAWN TO BE INSTALLED BY DEVELOPER

LOCAL RESIDENTIAL WITH DETACHED WALKS (NO ALLEY)

NOT TO SCALE

COMMERCE CITY
DEPARTMENT OF PUBLIC WORKS
ENGINEERING CONSTRUCTION STANDARDS

APPROVAL:

Maria A. Fisher

05-27-16

CITY ENGINEER

DATE

ROADWAY AND PARKING DETAILS
TYPICAL STREET SECTIONS

DETAIL NO.

307-07



S:\Trainproj\100049520 - Commerce City Engineering Standards\Design\Drawings\Reference_Files\CCC DWG\300-01 thru 300-07 (Roadway & Parking Typical Sections).dwg

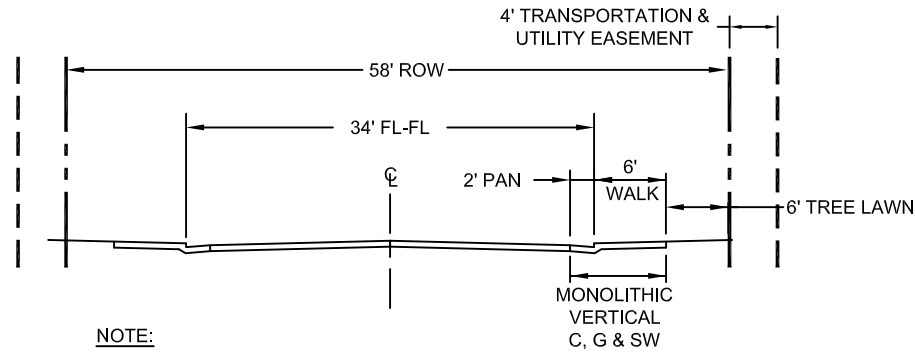

- NOTE:**
1. STRIPING NOT REQUIRED
 2. ON STREET PARKING ALLOWED

LOCAL RESIDENTIAL WITH ATTACHED WALKS (NO ALLEY)

NOT TO SCALE

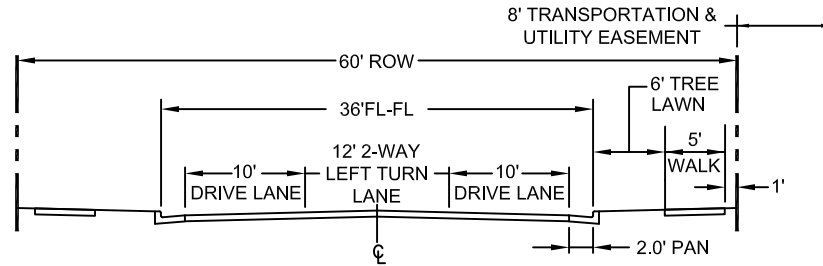

- NOTES:**
1. NO ON STREET PARKING
 2. STRIPE 2-WAY LEFT TURN LANE
 3. FOR COMMERCIAL OR HIGH DENSITY RESIDENTIAL STREETS

LOCAL COMMERCIAL

NOT TO SCALE

COMMERCE CITY
DEPARTMENT OF PUBLIC WORKS
ENGINEERING CONSTRUCTION STANDARDS

APPROVAL:
Maria A. Fisher 05-27-16
CITY ENGINEER DATE

ROADWAY AND PARKING DETAILS
TYPICAL STREET SECTIONS

DETAIL NO.
307-08



S:\Trainproj\100049520 - Commerce City Engineering Standards\Drawings\Reference_Files\CCC DWG\300-01 thru 300-07 (Roadway & Parking Typical Sections).dwg

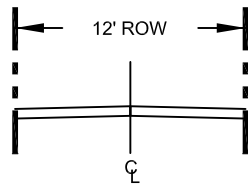

RESIDENTIAL ALLEY

1"=10'

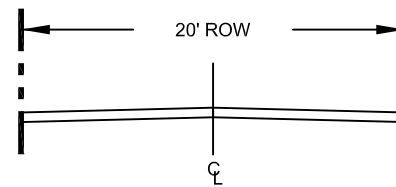

COMMERCIAL ALLEY

1"=10'

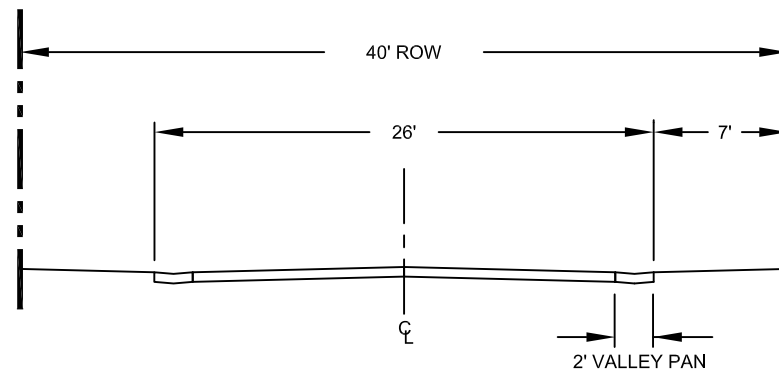

NOTES:

- 1. NO ON STREET PARKING
- 2. STRIPING NOT REQUIRED
- 3. FOR ACCESS TO 1/2 ACRE OR LARGER LOTS

LOCAL RURAL

1"=10'

SEE THE PAVEMENT DESIGN SECTION OF THE ENGINEERING CONSTRUCTION STANDARDS AND SPECIFICATIONS FOR REQUIRED PAVEMENT SECTIONS.

COMMERCE CITY
 DEPARTMENT OF PUBLIC WORKS
 ENGINEERING CONSTRUCTION STANDARDS

APPROVAL:

Maria A. Fisher

05-27-16

CITY ENGINEER

DATE

ROADWAY AND PARKING DETAILS
 TYPICAL STREET SECTIONS

DETAIL NO.

307-09



W:\Design\Drawings\Reference_Files\CCC DWG\307-10 (Right In - Right Out).dwg

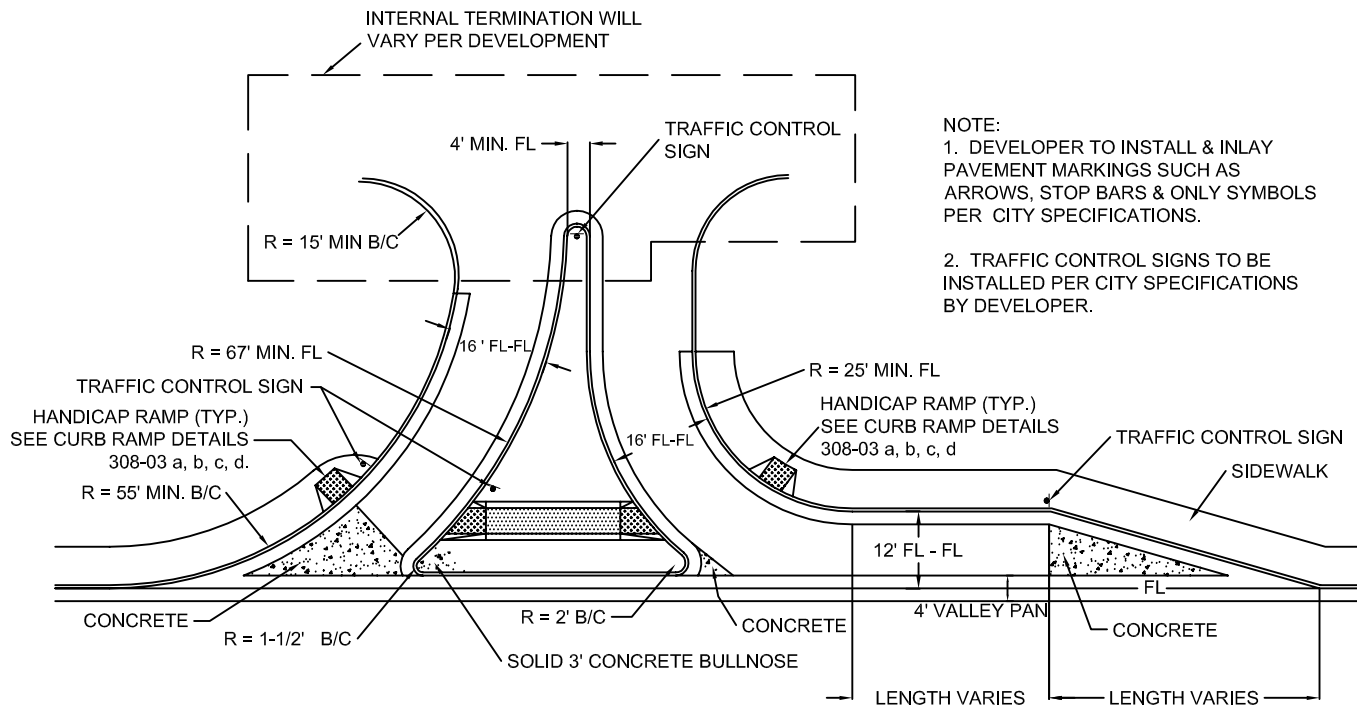

NOTE:
 1. DEVELOPER TO INSTALL & INLAY PAVEMENT MARKINGS SUCH AS ARROWS, STOP BARS & ONLY SYMBOLS PER CITY SPECIFICATIONS.
 2. TRAFFIC CONTROL SIGNS TO BE INSTALLED PER CITY SPECIFICATIONS BY DEVELOPER.

COMMERCE CITY
 DEPARTMENT OF PUBLIC WORKS
 ENGINEERING CONSTRUCTION STANDARDS

APPROVAL:
Maria R. Fisher 11-14-16
 CITY ENGINEER DATE

TYPICAL RIGHT IN - RIGHT OUT

DETAIL NO.
 307-10



S:\Trainproj\100049520 - Commerce City Engineering Standards\Design\Drawings\Reference_Files\CCC DWG\307-11 (Eyebrow Treatment).dwg

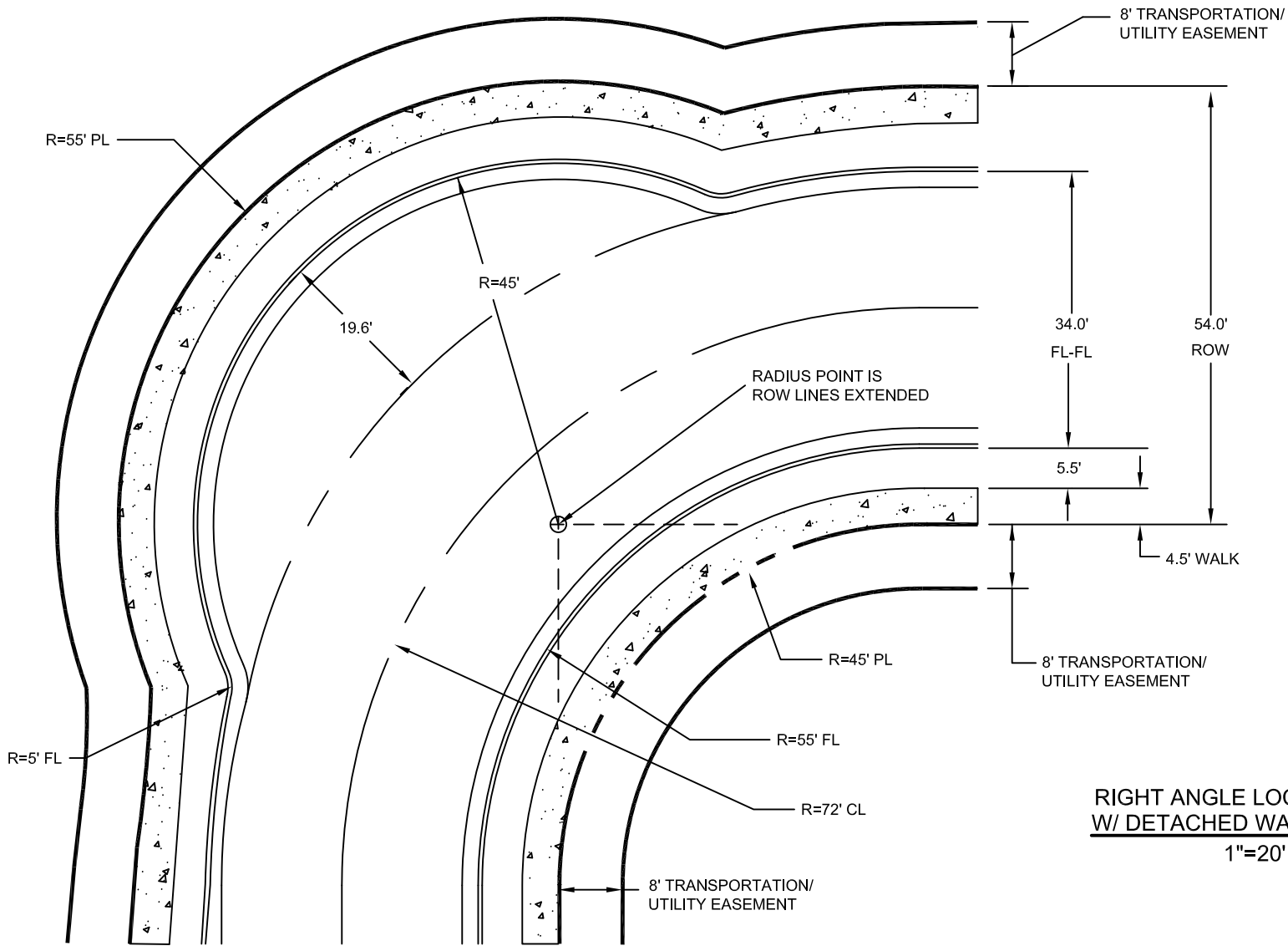

**RIGHT ANGLE LOCAL STREET
W/ DETACHED WALK (54'ROW)**
1"=20'

COMMERCE CITY
DEPARTMENT OF PUBLIC WORKS
ENGINEERING CONSTRUCTION STANDARDS

APPROVAL:
Maria R. Fisher 05-27-16
CITY ENGINEER DATE

EYEBROW TREATMENT

DETAIL NO.
307-11



S:\Trainproj\100049520 - Commerce City Engineering Standards\Design Drawings\Reference_Files\CCC DWG\307-12 (Cul-de-sac).dwg

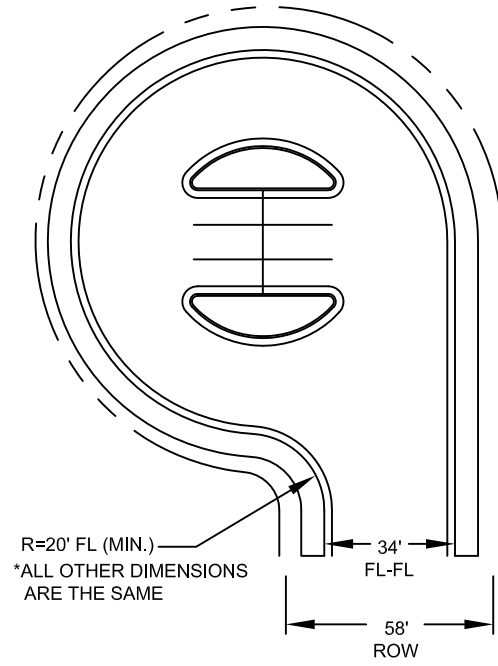
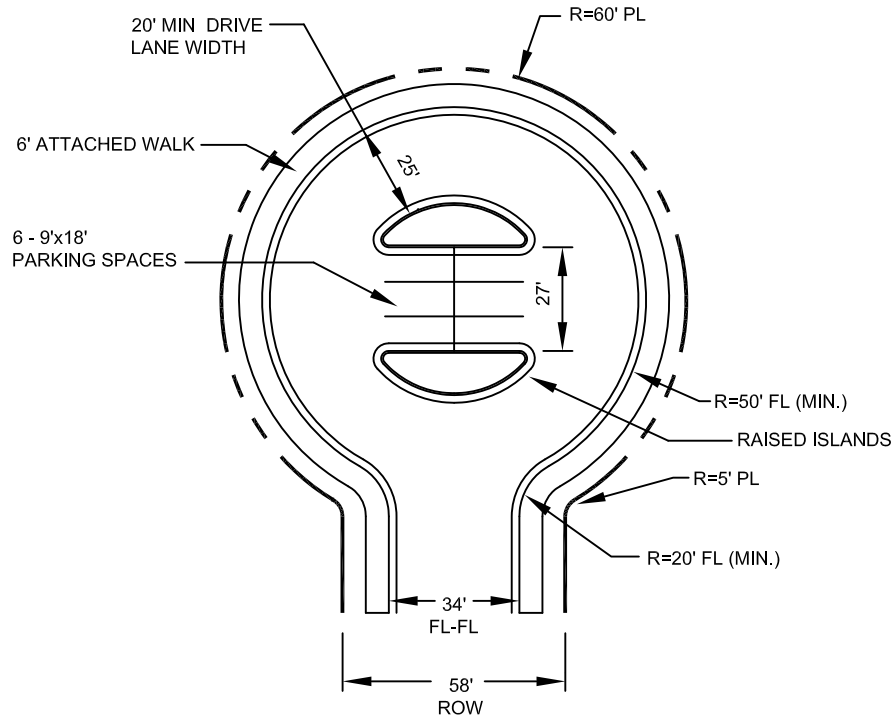

**CUL-DE-SAC
WITH ATTACHED SIDEWALK**
NOT TO SCALE

COMMERCE CITY
DEPARTMENT OF PUBLIC WORKS
ENGINEERING CONSTRUCTION STANDARDS

APPROVAL:
Maria A. Fisher 05-27-16
CITY ENGINEER DATE

**CUL-DE-SAC W/ATTACHED
SIDEWALK (1 OF 2)**

DETAIL NO.
307-12



S:\Training\100049520 - Commerce City Engineering Standards\Design\Drawings\Reference_Files\CCC DWG\307-12 (Cul-de-sac).dwg

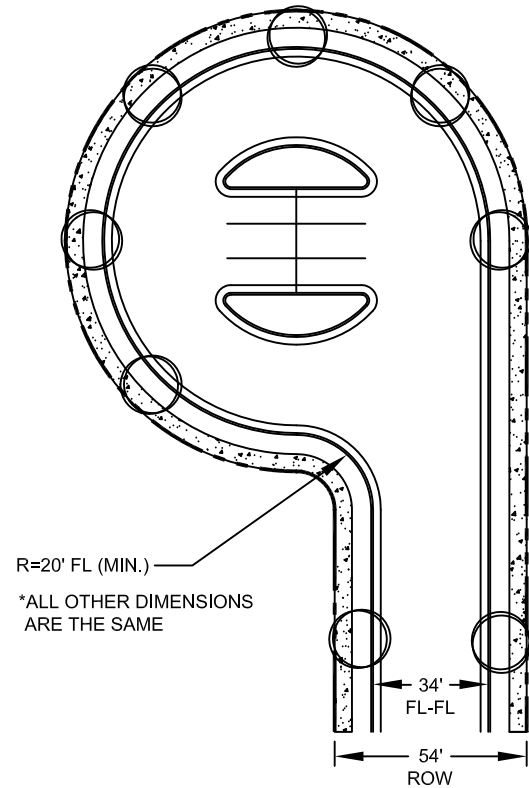
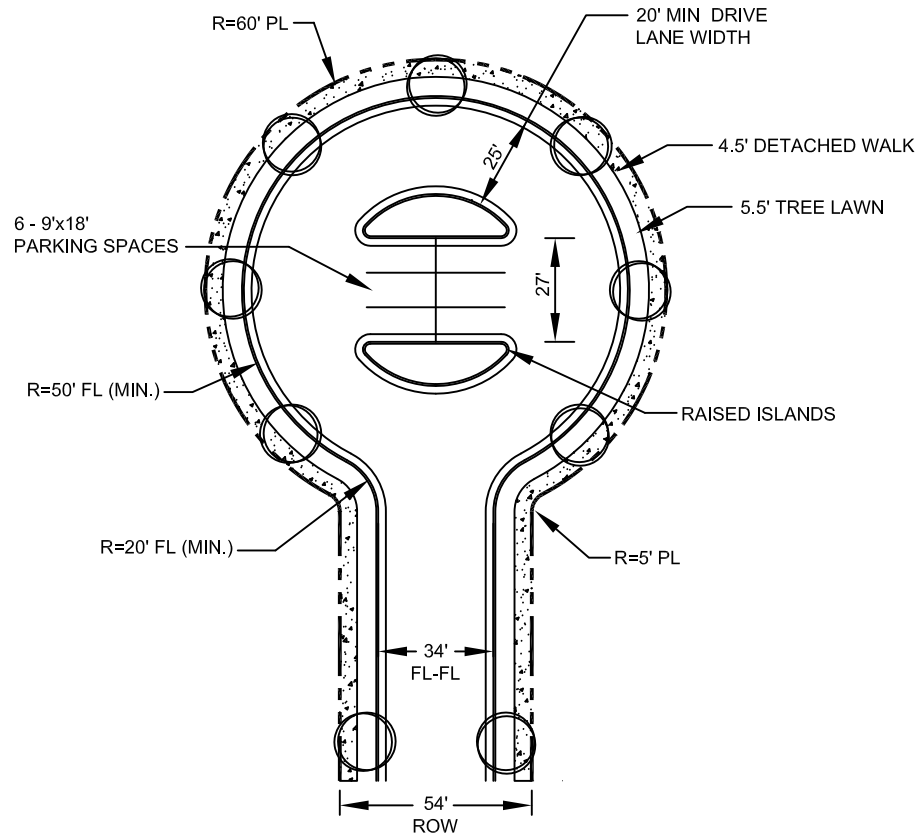

**CUL-DE-SAC
WITH DETACHED SIDEWALK**
NOT TO SCALE

COMMERCE CITY
DEPARTMENT OF PUBLIC WORKS
ENGINEERING CONSTRUCTION STANDARDS

APPROVAL:
Maria A. Fisher 05-27-16
CITY ENGINEER DATE

**CUL-DE-SAC W/ATTACHED
SIDEWALK (2 OF 2)**

DETAIL NO.
307-12



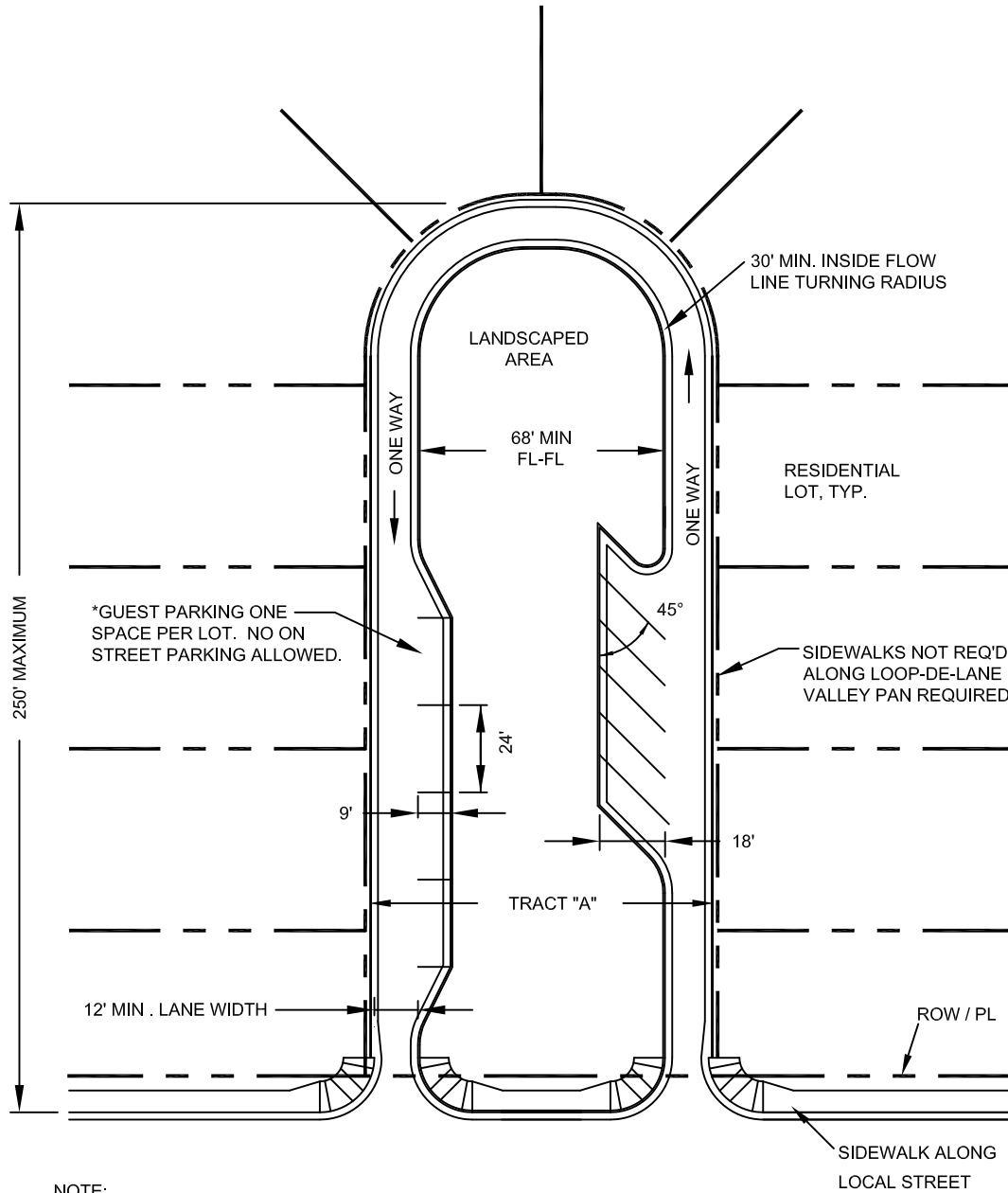

NOTE:
 *1. EITHER ANGLED OR PARALLEL PARKING IS ALLOWED.
 BOTH ARE SHOWN FOR ILLUSTRATION PURPOSES ONLY.

LOOP-DE-LANE

1"=50'

S:\Tranproj\1000-49520 - Commerce City Engineering Standards\Design\Drawings\Reference_Files\CCC DWGs\307-13 (Loop-de-lane).dwg

COMMERCE CITY
 DEPARTMENT OF PUBLIC WORKS
 ENGINEERING CONSTRUCTION STANDARDS

APPROVAL:
Maria A. Fisher 05-27-16
 CITY ENGINEER DATE

LOOP-DE-LANE

DETAIL NO.
 307-13



CITY ENGINEER AND EMERGENCY
ACCESS APPROVAL REQUIRED
PRIOR TO USE OF HAMMERHEAD
CUL-DE-SAC

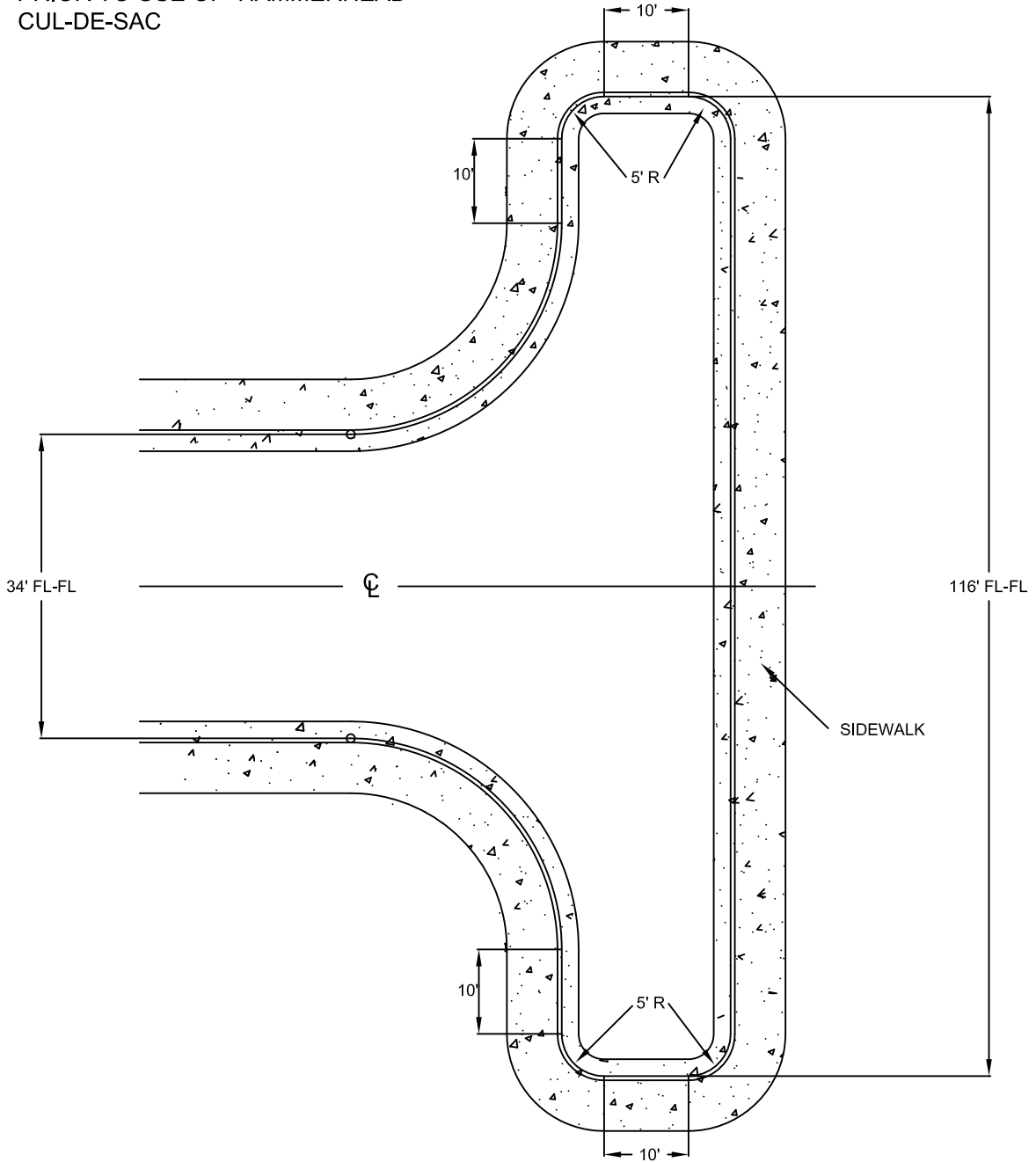

S:\Tranproj\100049520 - Commerce City Engineering Standards\Design\Drawings\References_Files\CCC DWGs\307-14 (Typical Hammerhead Cul-De-Sac).dwg

COMMERCE CITY
DEPARTMENT OF PUBLIC WORKS
ENGINEERING CONSTRUCTION STANDARDS

APPROVAL:

Maria A. Fisher

05-27-16

CITY ENGINEER

DATE

TYPICAL HAMMERHEAD
CUL-DE-SAC

DETAIL NO.
307-14



S:\Transport\100049520 - Commerce City Engineering Standards\Design\Drawings\Reference_Files\CCC DWGs\307-15 (Roundabout).dwg

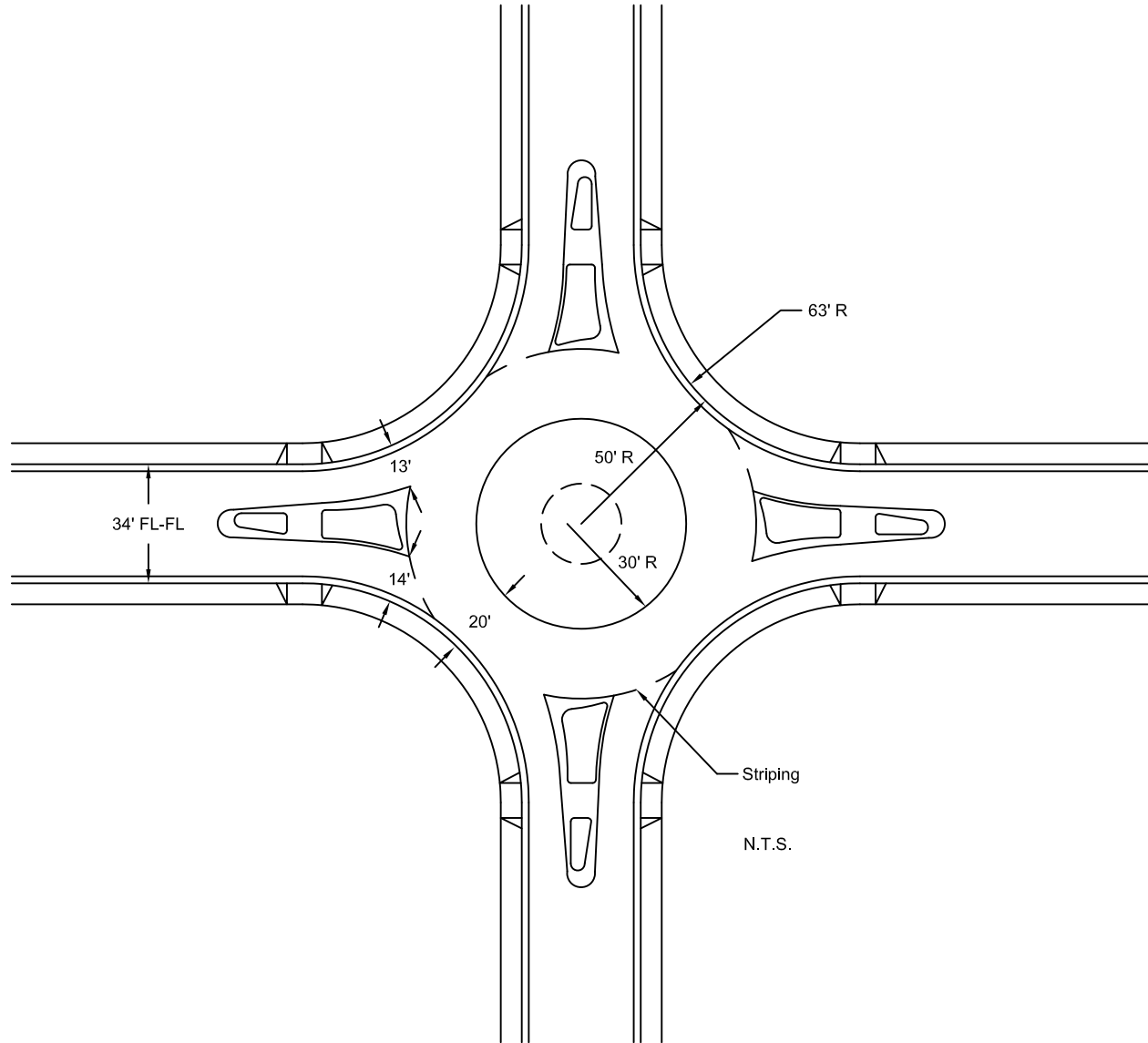

COMMERCE CITY
DEPARTMENT OF PUBLIC WORKS
ENGINEERING CONSTRUCTION STANDARDS

APPROVAL:
Maria A. Flores 05-27-16
CITY ENGINEER DATE

ROUNDABOUT

DETAIL NO.
307-15



S:\Transport\100049520 - Commerce City Engineering Standards\Design\Drawings\Reference_Files\CCC DWG\307-16 (Traffic Calming Island with Neckdown).dwg

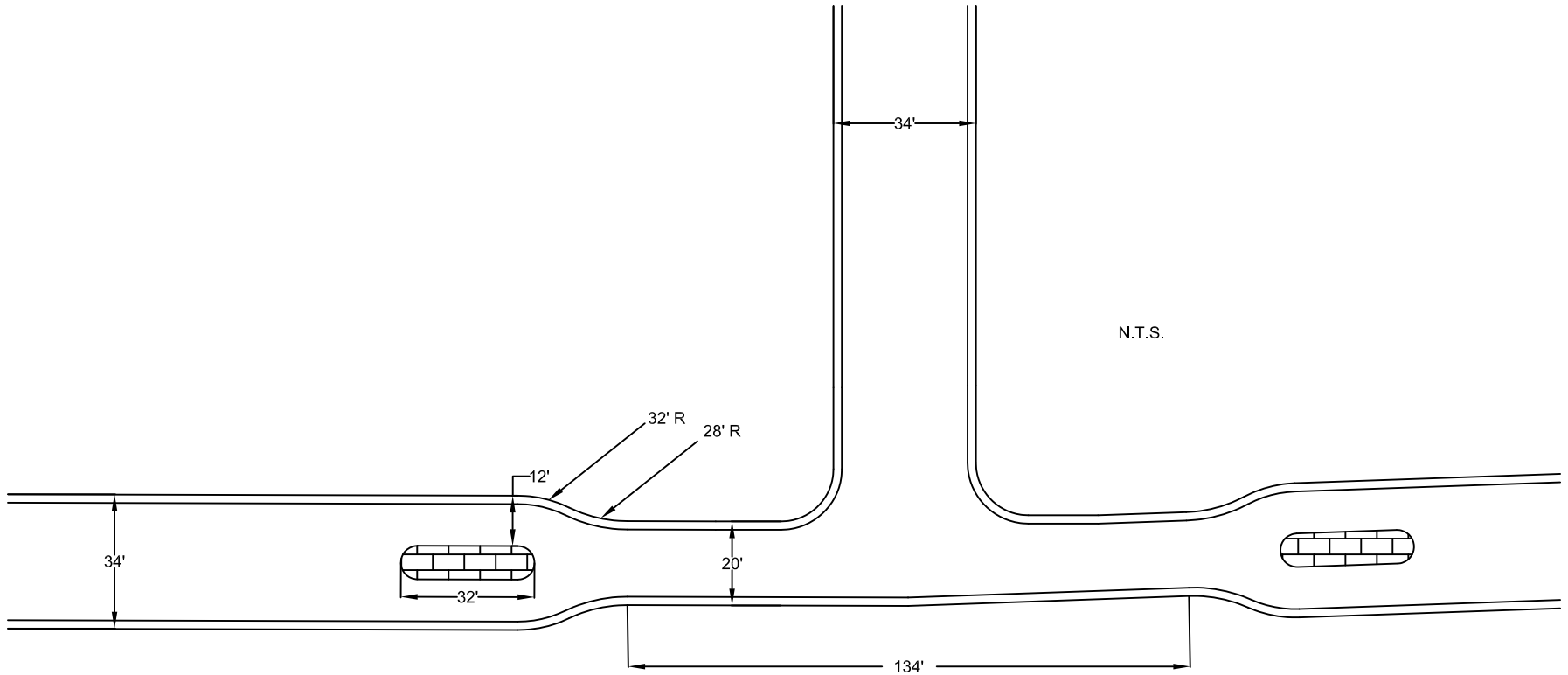

COMMERCE CITY
DEPARTMENT OF PUBLIC WORKS
ENGINEERING CONSTRUCTION STANDARDS

TRAFFIC CALMING ISLAND
WITH NECKDOWN

APPROVAL:

Maria A. Flores

CITY ENGINEER

05-27-16

DATE

DETAIL NO.

307-16



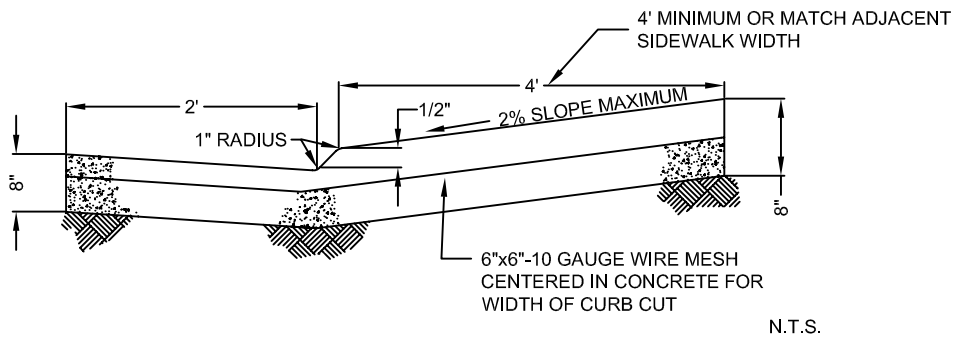
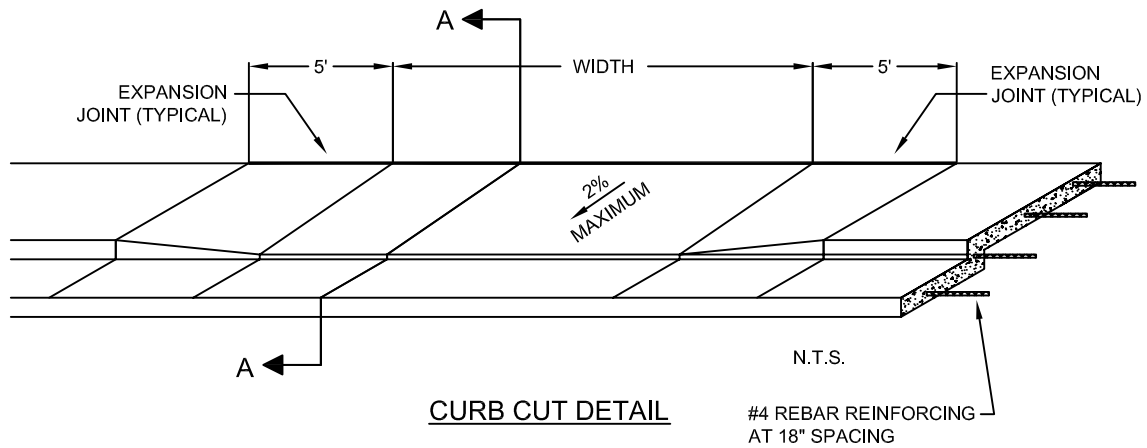

NOTES:

1. REINFORCEMENT IS REQUIRED FOR INDUSTRIAL AND HEAVY COMMERCIAL DRIVE CUTS.
2. EXPANSION JOINTS SHALL BE INSTALLED WHEN ABUTTING EXISTING CONCRETE OR FIXED STRUCTURE. EXPANSION JOINT MATERIAL SHALL BE 1/2" THICK AND SHALL EXTEND THE FULL DEPTH OF THE CONTACT SURFACE.
3. CONCRETE THICKNESS SHALL BE 6" FOR RESIDENTIAL AREAS AND 8" FOR ALL OTHERS.
4. 18" LONG #4 EPOXY COATED REBAR REINFORCING SHALL BE USED TO PIN NEW CONCRETE TO EXISTING CONCRETE. SPACING SHALL BE 18-INCHES.
5. IF 2% MAXIMUM SLOPE CANNOT BE MET, A MOUNTABLE CURB WILL BE REQUIRED AND A 2% MAXIMUM SLOPE SHALL BE MAINTAINED. SEE DETAIL 308-06

COMMERCE CITY
DEPARTMENT OF PUBLIC WORKS
ENGINEERING CONSTRUCTION STANDARDS

APPROVAL:

Maria A. Fisher

CITY ENGINEER

11-14-16

DATE

CURB CUT DETAIL

DETAIL NO.
308-01



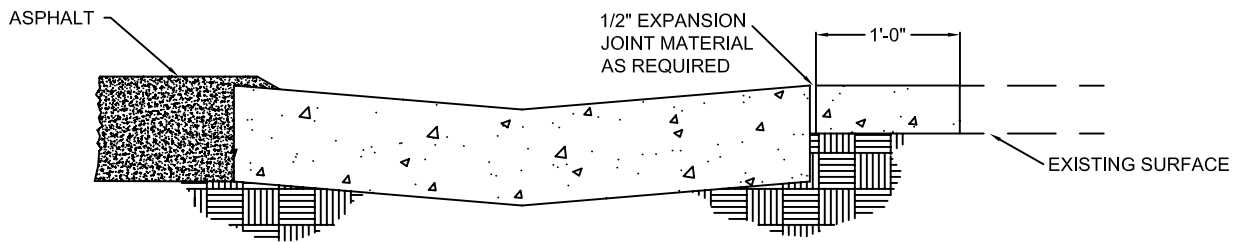
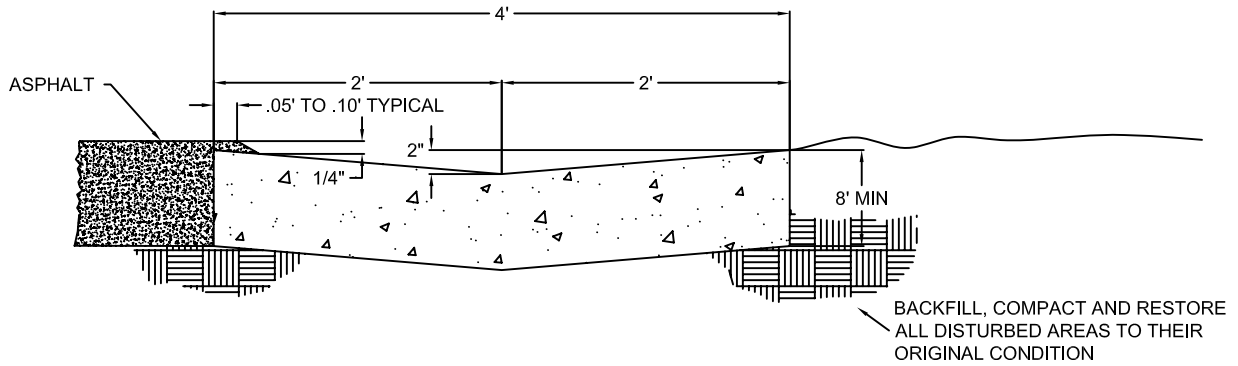

S:\Tranproj\1000-49520 - Commerce City Engineering Standards\Design\Drawings\Reference_Files\CCC DWGs\308-02 (Valley Pan).dwg

COMMERCE CITY
DEPARTMENT OF PUBLIC WORKS
ENGINEERING CONSTRUCTION STANDARDS

APPROVAL:
Maria A. Fisher 05-27-16
CITY ENGINEER DATE



VALLEY PAN

DETAIL NO.
308-02

GENERAL NOTES

1. THE DETECTABLE WARNINGS SHALL BE INSTALLED AT SIDEWALK TO STREET TRANSITIONS. THEY SHALL HAVE A TRUNCATED DOME SURFACE. THE DOMES SHALL BE IN A SQUARE GRID PATTERN AND ALIGNED WITH PEDESTRIAN TRAFFIC.
2. ALL DETECTABLE WARNING AREAS SHALL START A MINIMUM OF 6 IN. FROM THE FLOW LINE OF THE CURB AND NOT BE MORE THAN A MAXIMUM OF 8 IN. (WITH EXCEPTION FOR THE TYPE 1B MODIFIED AND TYPE 3B MODIFIED AS THIS DIMENSION MAY BE GREATER THAN 8 INCHES ON ONE SIDE OF THE RADIUS) FROM ANY POINT ON THE FLOW LINE OF THE CURB. ALL DETECTABLE WARNING AREAS SHALL BE 2 FT. IN LENGTH AND COVER THE COMPLETE WIDTH OF THE RAMP AREA ONLY.
3. RAMP SLOPES SHALL BE 8.3% OR FLATTER. THE DETECTABLE WARNING SLOPES SHALL BE 5% OR FLATTER.
4. MINIMUM SIDEWALK WIDTH IS 4 FT.
5. DO NOT INSTALL DRAINAGE STRUCTURES, TRAFFIC SIGNAL EQUIPMENT, JUNCTION BOXES, AND OTHER OBSTRUCTIONS IN FRONT OF THE RAMP ACCESS AREAS.
6. CONSTRUCTION OF THE CONCRETE PEDESTRIAN CURB ADJACENT TO THE RAMP AREAS SHALL BE INCLUDED IN THE BID PRICE OF THE CONCRETE CURB RAMP.
7. DETECTABLE WARNINGS SHALL MEET SECTION 705 OF THE USDOT ADA STANDARDS FOR TRANSPORTATION FACILITIES.
8. IF THE PLACEMENT OF A PEDESTRIAN PUSH BUTTON ASSEMBLY ON A TRAFFIC SIGNAL MAST POLE WILL NOT BE WITHIN EASY REACH (10" OR LESS AND UNOBSTRUCTED) OF PEDESTRIANS (IN ACCORDANCE WITH THE AMERICANS WITH DISABILITIES ACT), THEN A SEPARATE PEDESTRIAN PUSH BUTTON POST ASSEMBLY (PPBPA) SHALL BE INSTALLED WITHIN EASY REACH. THE PPBPA SHALL MEET THE PROVISIONS FOUND IN "SECTION 4E.08 THROUGH 4E.13 - PEDESTRIAN DETECTORS" OF THE 2009 MUTCD MANUAL WITH REVISIONS 1 AND 2.
9. WHERE SPACE IS LIMITED OR GRADE IS AN ISSUE, A 10% SLOPE MAY BE USED ON FLARED SIDES.
10. THE SLOPES CAN BE LOWER THAN WHAT IS SHOWN BUT THEY SHALL NOT EXCEED THESE VALUES.
11. CURB RAMP TYPE 1A DIAGONAL (ON THE APEX) IS UNACCEPTABLE IN NEW CONSTRUCTION. TYPICALLY, TWO CURB RAMPS AS IN TYPE 1B, MUST BE PROVIDED AT EACH STREET CORNER.
ADA TITLE II 28 C.F.R. SECTION 35.151(B) STATES:
ALTERATIONS HAVE TO BE MADE READILY ACCESSIBLE, WITHIN THE IMPACTING PROJECT, TO THE MAXIMUM EXTENT FEASIBLE (MEF).

THEREFORE, A SINGLE, DIAGONAL CURB RAMP TYPE 1A WILL ONLY BE PERMITTED ON ALTERATION PROJECTS WITH MEF JUSTIFICATION DOCUMENTATION.
12. THE CURB RAMP (EXCLUDING ANY FLARED SIDES) OR BLENDED TRANSITION SHALL BE CONTAINED WHOLLY WITHIN THE WIDTH OF THE CROSSWALK AND/OR PEDESTRIAN STREET CROSSING THE RAMP SERVES.
13. WING SURFACES SHALL BE TEXTURED WITH A COARSE BROOMED SURFACE ONLY.

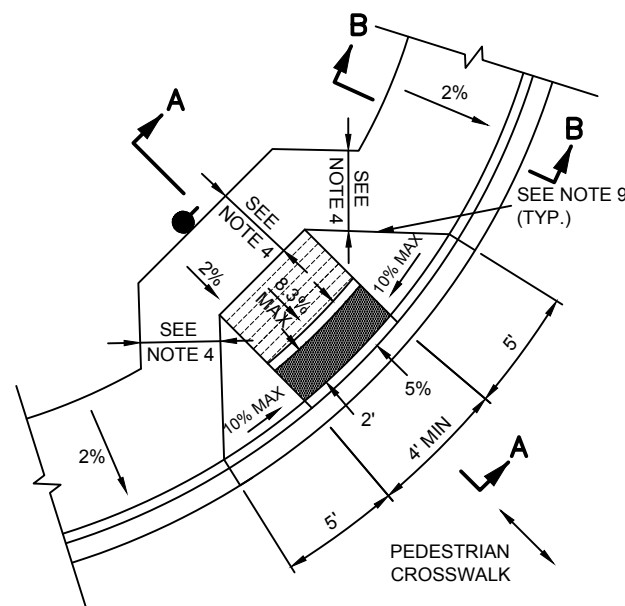

CURB RAMP TYPE 1A
SEE NOTE 11

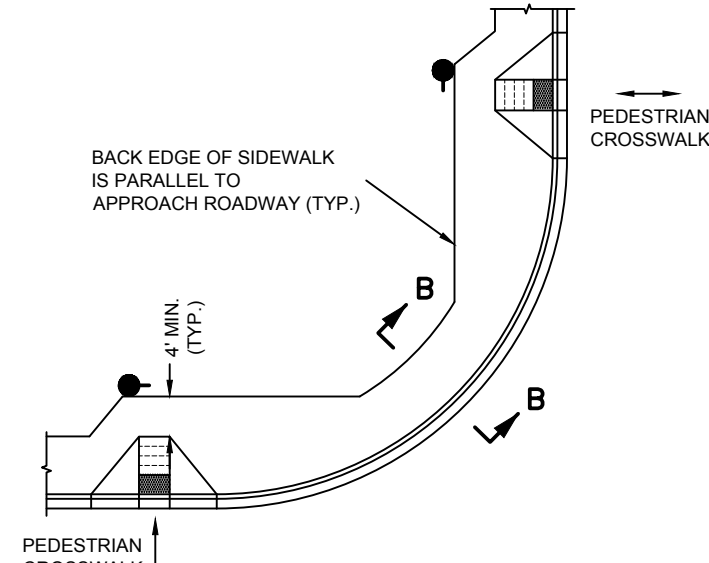

CURB RAMP TYPE 1B
SEE NOTE 11

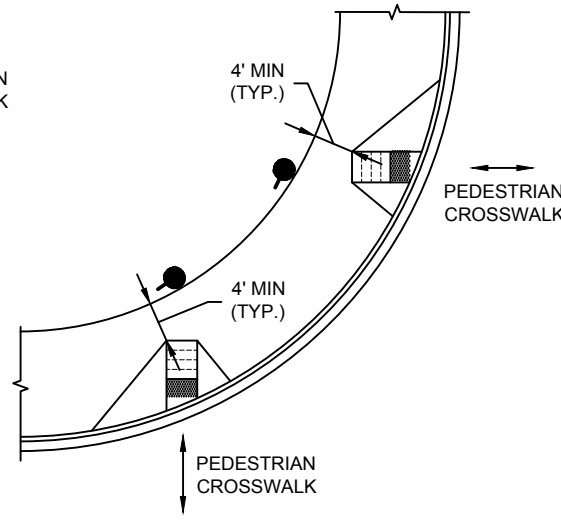

CURB RAMP TYPE 1B MODIFIED
USE ONLY IF EXISTING ROW DICTATES.
GRADE BREAK SHALL NOT BE PERMITTED ON THE SURFACE OF THE RAMP RUNS AND TURNING SPACES. SURFACE THAT MEET AT GRADE BREAKS SHALL BE FLUSH.
SEE NOTE 11.

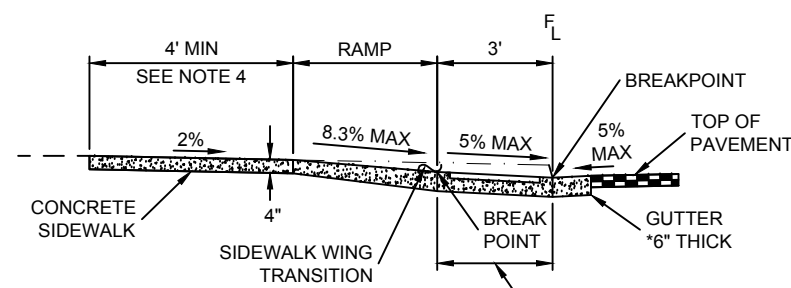

SECTION A-A

* INCREASE TO 8" FOR BRICK PAVERS.

ADA DETECTABLE WARNING DEVICE CAST IRON TRUNCATED DOMES. BRICK AND STAMPED CONCRETE ARE NOT ALLOWED

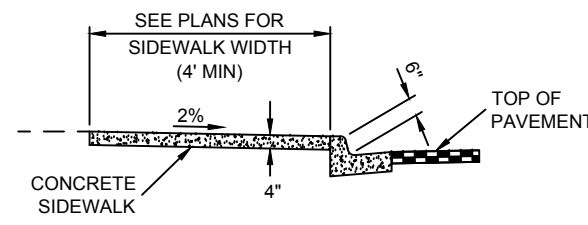

SECTION B-B

PEDESTRIAN PUSH BUTTON POST ASSEMBLY (PPBPA)

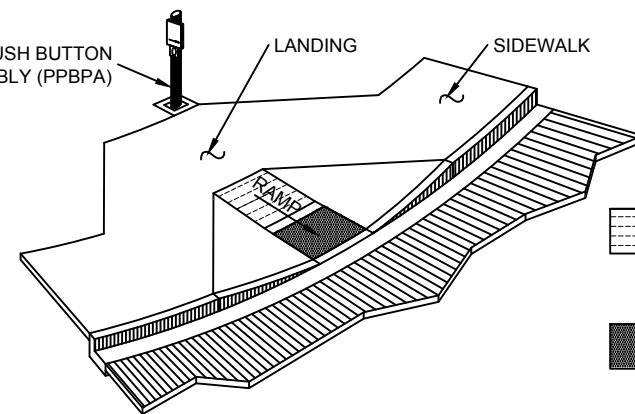

ISOMETRIC VIEW

SHOWN WITH PEDESTRIAN PUSH BUTTON POST ASSEMBLY (PPBPA)

RAMP SURFACE SHALL BE TEXTURED WITH A COARSE BROOMED FINISH AND SCORED WITH GROOVES (," BY ,") SPACED 6" INCHES ON CENTER

ADA DETECTABLE WARNING DEVICE CAST IRON TRUNCATED DOMES. BRICK AND STAMPED CONCRETE ARE NOT ALLOWED

PEDESTRIAN PUSH BUTTON PUSH ASSEMBLY (PPBPA). SEE NOTE 8. SEE STANDARD PLAN S-614-9 FOR PPBPA DETAILS. SEE PLANS FOR LOCATIONS THE SIGN FACE SHALL BE PARALLEL TO THE CROSSWALK.

MFG'S:
EAST JORDAN IRON WORKS, INC. 1-800-874-4100
NEENAH FOUNDRY CO. 1-800-694-4660

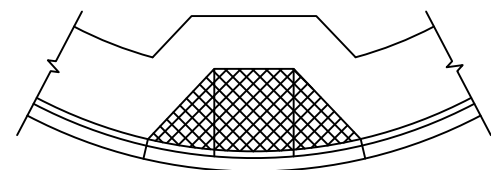

RAMP PAY AREA

FOR CURB RAMPS TYPE 1A AND 1B

C:\Division Information\Engineering Documents\Engineering and Construction\COMMERCE CITY\CAD files\2016 Updated Files\308-03 (Curb Ramps).dwg

COMPUTER FILE INFORMATION	
Creation Date: 03/10/2016	Initials: CJC
Last Modification Date: 5/26/2016	Initials: CJC
Full Path: WWW.C3GOV.COM	
Drawing Name: \$FILESS	
Scale: \$SCALESHORT\$	Units: ENGLISH

APPROVAL	
	12-15-17
CITY ENGINEER	DATE

CITY OF COMMERCE CITY

Department of Public Works
8602 Rosemary St.
Commerce City, CO 80022
Ph: 303-289-8150

CURB RAMPS
ENGINEERING CONSTRUCTION STANDARDS

DETAIL NO. 308-03a
Sheet No. 1 of 4

C:\Division Information\Engineering Documents\Engineering and Construction\COMMERCE CITY\CAD Files\2016 Updated Files\308-03 (Curb Ramps).dwg

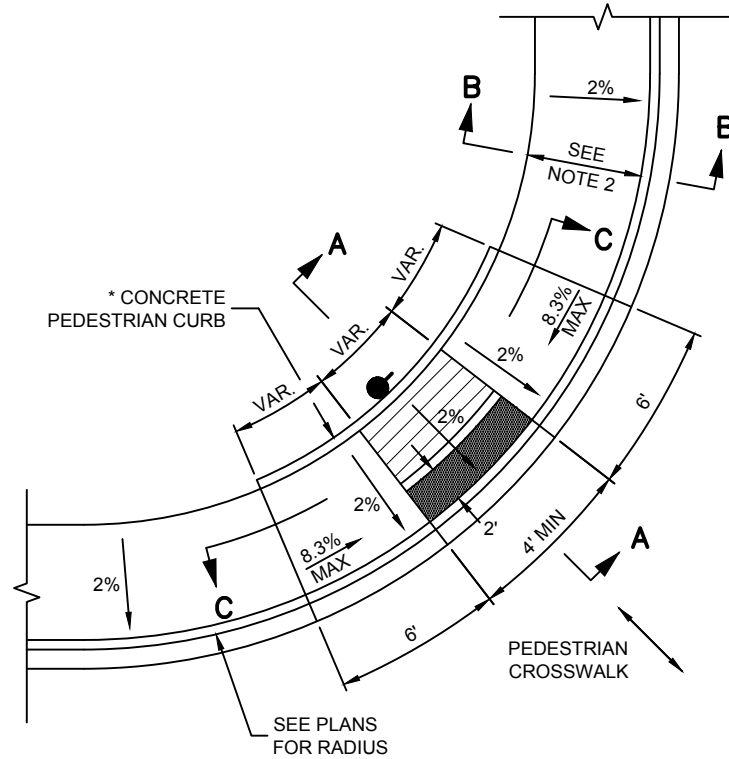

CURB RAMP TYPE 2A
SEE NOTE 3

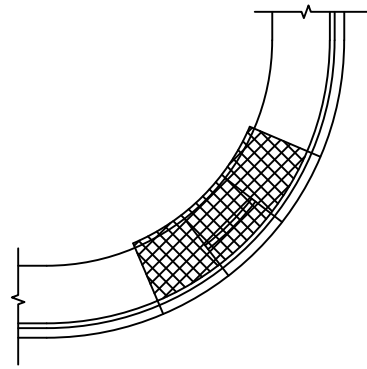

RAMP PAY AREA
FOR CURB RAMPS
TYPE 2A AND 2B
* INCLUDES CONCRETE PEDESTRIAN
CURB AS SHOWN

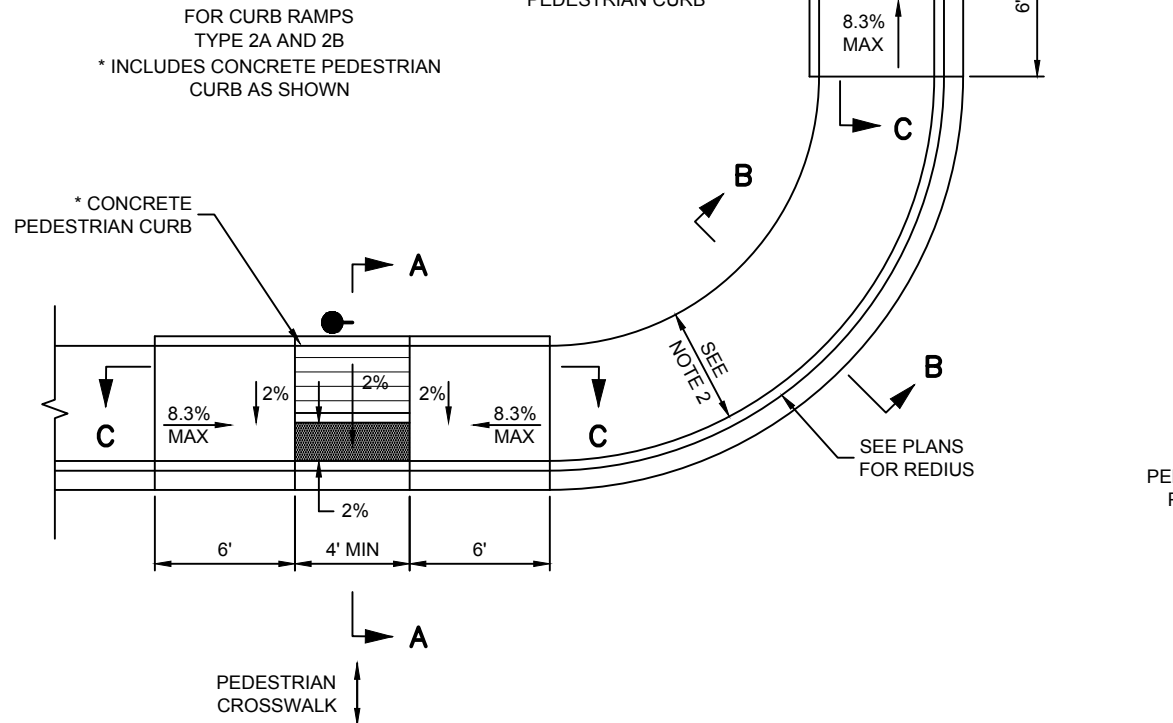

CURB RAMP TYPE 2B
SEE NOTE 3

- GENERAL NOTES**
- CURB RAMP TYPE 2B MAY BE USED IN MID-BLOCK.
 - MINIMUM SIDEWALK WIDTH IS 4 FT.
 - CURB RAMP TYPE 2A DIAGONAL (ON THE APEX) IS UNACCEPTABLE IN NEW CONSTRUCTION. TYPICALLY, TWO CURB RAMPS AS IN TYPE 2B, MUST BE PROVIDED AT EACH STREET CORNER.
ADA TITLE II 28 C.F.R. SECTION 35.151(B) STATES:
ALTERATIONS HAVE TO BE MADE READILY ACCESSIBLE, WITHIN THE IMPACTING PROJECT, TO THE MAXIMUM EXTENT FEASIBLE (MEF).
THEREFORE, A SINGLE, DIAGONAL CURB RAMP TYPE 2A WILL ONLY BE PERMITTED ON ALTERATION PROJECTS WITH MEF JUSTIFICATION DOCUMENTATION.

- RAMP SURFACE SHALL BE TEXTURED WITH A COARSE BROOMED FINISH AND SCORED WITH GROOVES (," BY ,") SPACED 6" INCHES ON CENTER
 - ADA DETECTABLE WARNING DEVICE CAST IRON TRUNCATED DOMES. BRICK AND STAMPED CONCRETE ARE NOT ALLOWED
 - PEDESTRIAN PUSH BUTTON PUSH ASSEMBLY (PPBPA). SEE NOTE 8. SEE STANDARD PLAN S-614-9 FOR PPBPA DETAILS. SEE PLANS FOR LOCATIONS. THE SIGN FACE SHALL BE PARALLEL TO THE CROSSWALK.
- MFG'S:
EAST JORDAN IRON WORKS, INC. 1-800-874-4100
NEENAH FOUNDRY CO. 1-800-694-4660

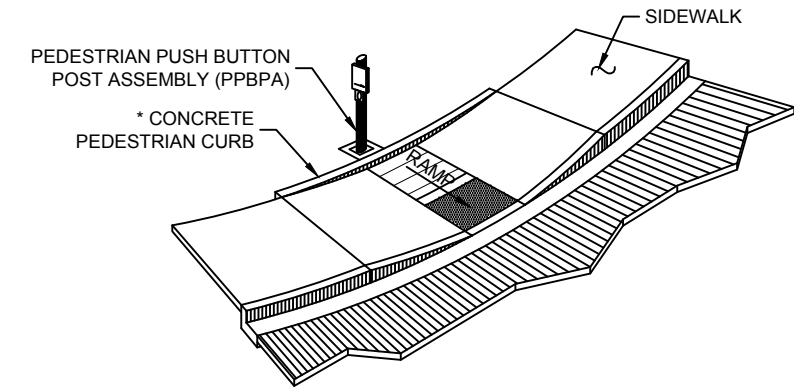

ISOMETRIC VIEW

SHOWN WITH PEDESTRIAN PUSH
BUTTON POST ASSEMBLY (PPBPA)

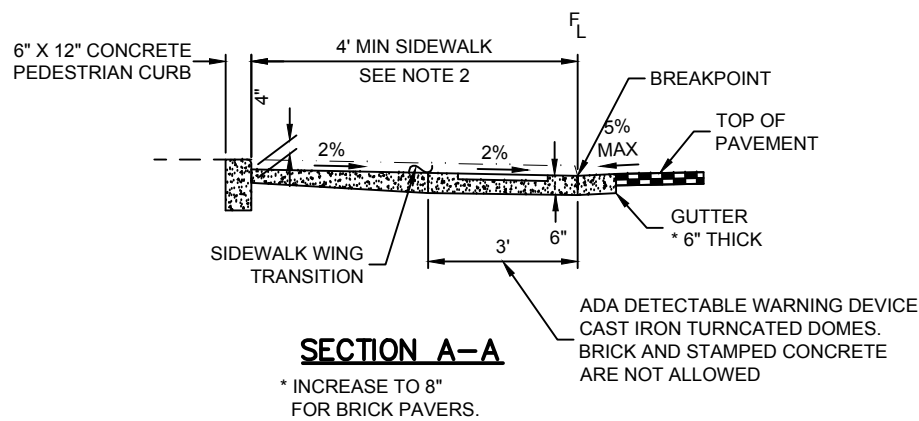

SECTION A-A
* INCREASE TO 8"
FOR BRICK PAVERS.

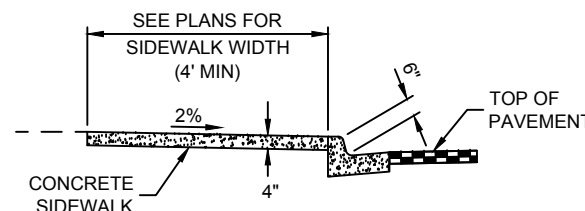

SECTION B-B

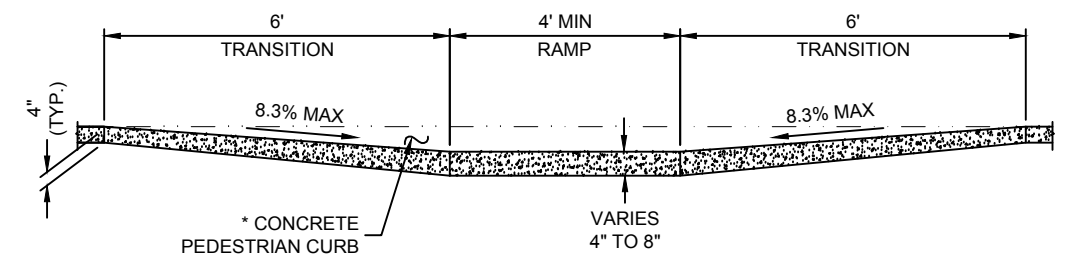

SECTION C-C

COMPUTER FILE INFORMATION	
Creation Date: 03/10/2016	Initials: CJC
Last Modification Date: 5/26/2016	Initials: CJC
Full Path: WWW.C3GOV.COM	
Drawing Name: \$FILE\$\$	
Scale: \$SCALESHORT\$	Units: ENGLISH

APPROVAL	
	12-15-17
CITY ENGINEER	DATE

CITY OF COMMERCE CITY



Department of Public Works
8602 Rosemary St.
Commerce City, CO 80022
Ph: 303-289-8150

CURB RAMPS
ENGINEERING CONSTRUCTION STANDARDS

DETAIL NO. 308-03b
Sheet No. 2 of 4

GENERAL NOTES

- CURB RAMP TYPE 3B MAY BE USED IN MID-BLOCK.
- MINIMUM SIDEWALK WIDTH IS 4 FT.
- CURB RAMP TYPE 3A DIAGONAL (ON THE APEX) IS UNACCEPTABLE IN NEW CONSTRUCTION. TYPICALLY, TWO CURB RAMP AS IN TYPE 3B, MUST BE PROVIDED AT EACH STREET CORNER.
 ADA TITLE II 28 C.F.R. SECTION 35.151(B) STATES:
 ALTERATIONS HAVE TO BE MADE READILY ACCESSIBLE, WITHIN THE IMPACTING PROJECT, TO THE MAXIMUM EXTENT FEASIBLE (MEF).
 THEREFORE, A SINGLE, DIAGONAL CURB RAMP TYPE 3A WILL ONLY BE PERMITTED ON ALTERATION PROJECTS WITH MEF JUSTIFICATION DOCUMENTATION.

-  RAMP SURFACE SHALL BE TEXTURED WITH A COARSE BROOMED FINISH AND SCORED WITH GROOVES (," BY ,") SPACED 6" INCHES ON CENTER
 -  ADA DETECTABLE WARNING DEVICE CAST IRON TRUNCATED DOMES. BRICK AND STAMPED CONCRETE ARE NOT ALLOWED
 -  PEDESTRIAN PUSH BUTTON PUSH ASSEMBLY (PPBPA). SEE NOTE 8. SEE STANDARD PLAN S-614-9 FOR PPBPA DETAILS. SEE PLANS FOR LOCATIONS THE SIGN FACE SHALL BE PARALLEL TO THE CROSSWALK.
- MFG'S:
 EAST JORDAN IRON WORKS, INC. 1-800-874-4100
 NEENAH FOUNDRY CO. 1-800-694-4660

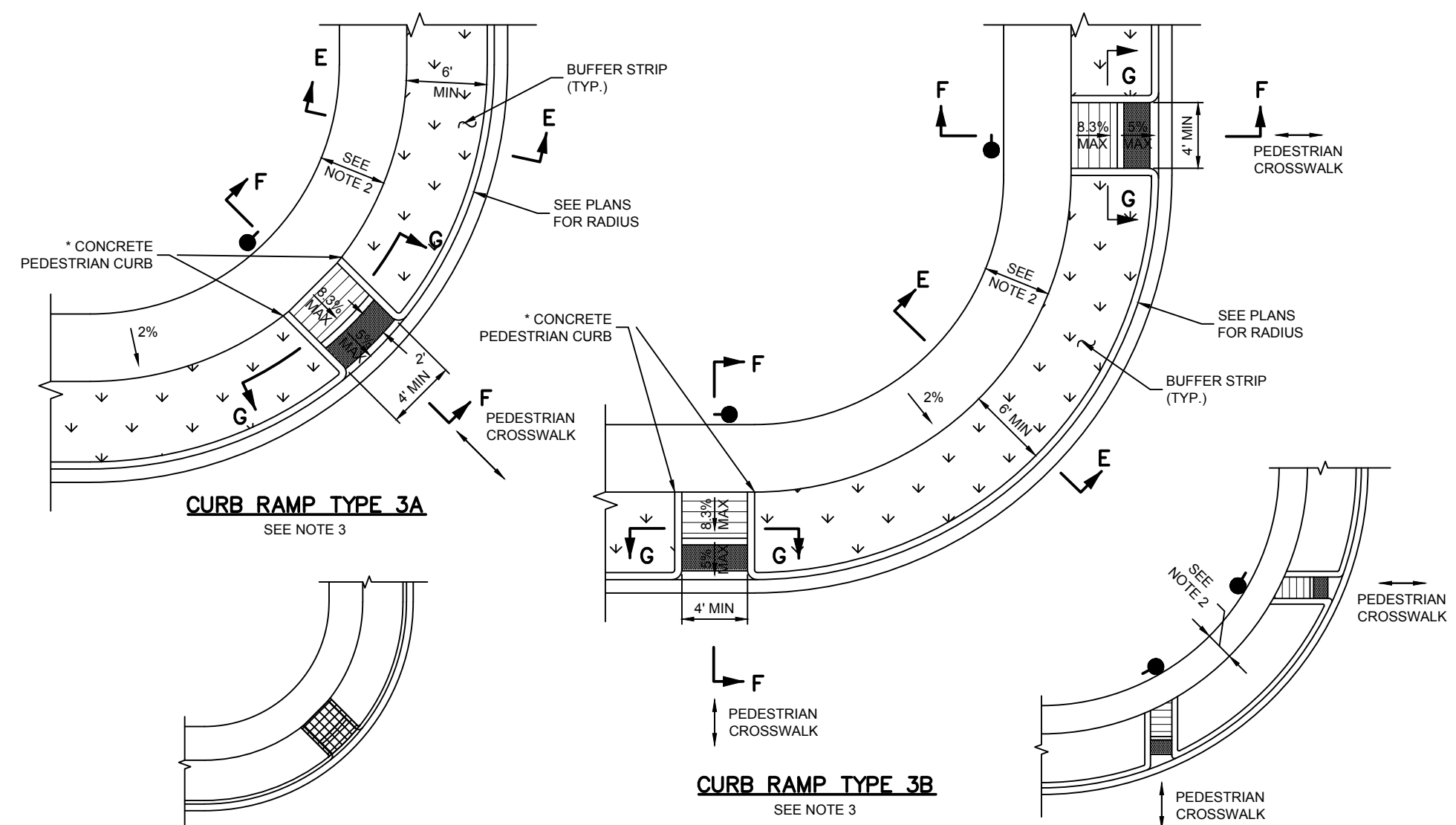

CURB RAMP TYPE 3A
SEE NOTE 3

CURB RAMP TYPE 3B
SEE NOTE 3

CURB RAMP TYPE 3B MODIFIED

USE ONLY IF EXISTING ROW DICTATES. GRADE BREAKS SHALL NOT BE PERMITTED ON THE SURFACE OF THE RAMP RUNS AND TURNING SPACES. SURFACE SLOPES THAT MEET AT GRADE BREAKS SHALL BE FLUSH. SEE NOTE 3.

RAMP PAY AREA
FOR CURB RAMPS TYPE 3A AND 3B
* INCLUDES CONCRETE PEDESTRIAN CURB AS SHOWN

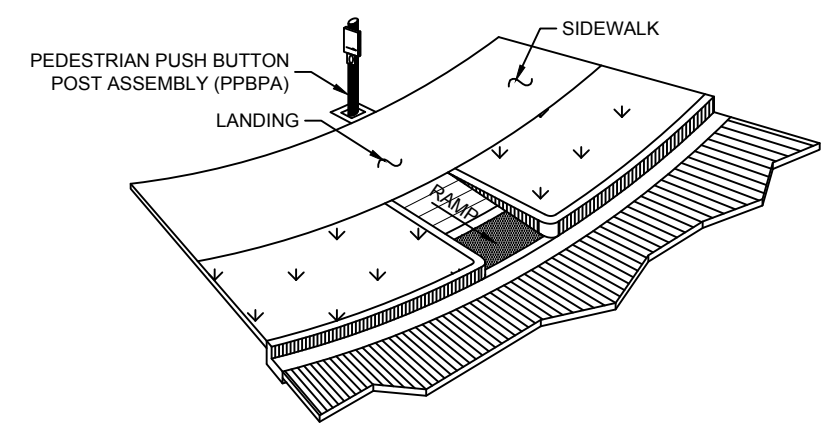

ISOMETRIC VIEW

SHOWN WITH PEDESTRIAN PUSH BUTTON POST ASSEMBLY (PPBPA)

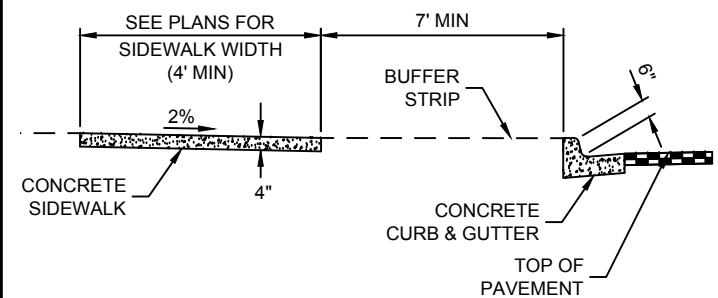

SECTION E-E

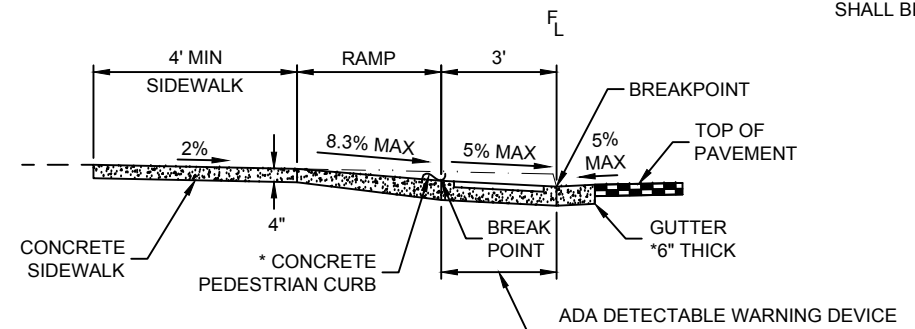

SECTION F-F

* INCREASE TO 8" FOR BRICK PAVERS.

C:\Division Information\Engineering Documents\Engineering and Construction\COMMERCE CITY\CAD files\2016 Updated Files\308-03 (Curb Ramps).dwg

COMPUTER FILE INFORMATION	
Creation Date: 03/10/2016	Initials: CJC
Last Modification Date: 5/26/2016	Initials: CJC
Full Path: WWW.C3GOV.COM	
Drawing Name: \$FILESS	
Scale: \$SCALESHORT\$	Units: ENGLISH

APPROVAL	
	12-15-17
CITY ENGINEER	DATE

CITY OF COMMERCE CITY



Department of Public Works
 8602 Rosemary St.
 Commerce City, CO 80022
 Ph: 303-289-8150

CURB RAMPS
ENGINEERING CONSTRUCTION STANDARDS

DETAIL NO. 308-03c
Sheet No. 3 of 4

GENERAL NOTES

1. MINIMUM SIDEWALK WIDTH IS 4 FT.
2. CURB RAMP TYPE 4A DIAGONAL (ON THE APEX) IS UNACCEPTABLE IN NEW CONSTRUCTION. TYPICALLY, TWO CURB RAMPS AS IN TYPE 4B, MUST BE PROVIDED AT EACH STREET CORNER.
 ADA TITLE II 28 C.F.R. SECTION 35.151(B) STATES:
 ALTERATIONS HAVE TO BE MADE READILY ACCESSIBLE, WITHIN THE IMPACTING PROJECT, TO THE MAXIMUM EXTENT FEASIBLE (MEF).
 THEREFORE, A SINGLE, DIAGONAL CURB RAMP TYPE 4A WILL ONLY BE PERMITTED ON ALTERATION PROJECTS WITH MEF JUSTIFICATION DOCUMENTATION.
3. WING SURFACES SHALL BE TEXTURED WITH A COARSE BROOMED SURFACE ONLY.

-  RAMP SURFACE SHALL BE TEXTURED WITH A COARSE BROOMED FINISH AND SCORED WITH GROOVES (," BY ,") SPACED 6" INCHES ON CENTER
 -  ADA DETECTABLE WARNING DEVICE CAST IRON TRUNCATED DOMES. BRICK AND STAMPED CONCRETE ARE NOT ALLOWED
 -  PEDESTRIAN PUSH BUTTON PUSH ASSEMBLY (PPBPA). SEE NOTE 8. SEE STANDARD PLAN S-614-9 FOR PPBPA DETAILS. THE SIGN FACE SHALL BE PARALLEL TO THE CROSSWALK.
- MFG'S:
 EAST JORDAN IRON WORKS, INC. 1-800-874-4100
 NEENAH FOUNDRY CO. 1-800-694-4660

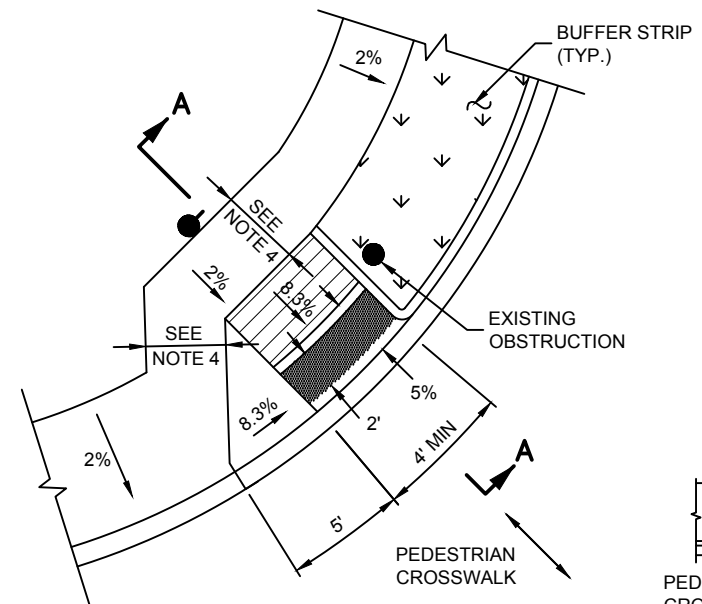

CURB RAMP TYPE 4A
SEE NOTE 2

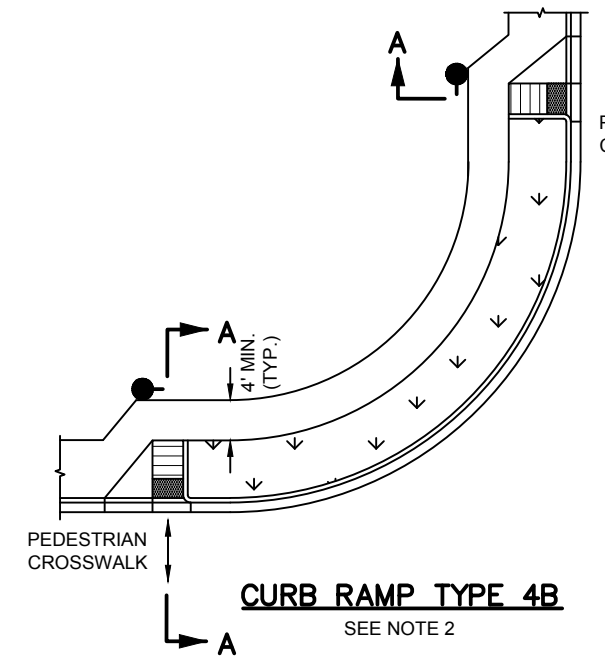

CURB RAMP TYPE 4B
SEE NOTE 2

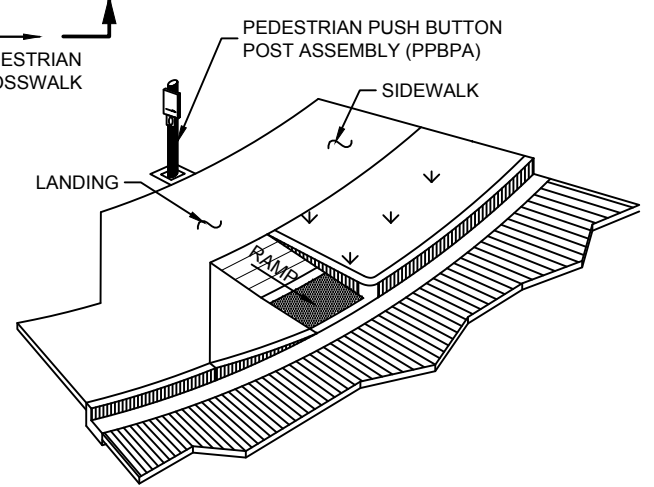

ISOMETRIC VIEW
SHOWN WITH PEDESTRIAN PUSH BUTTON POST ASSEMBLY (PPBPA)

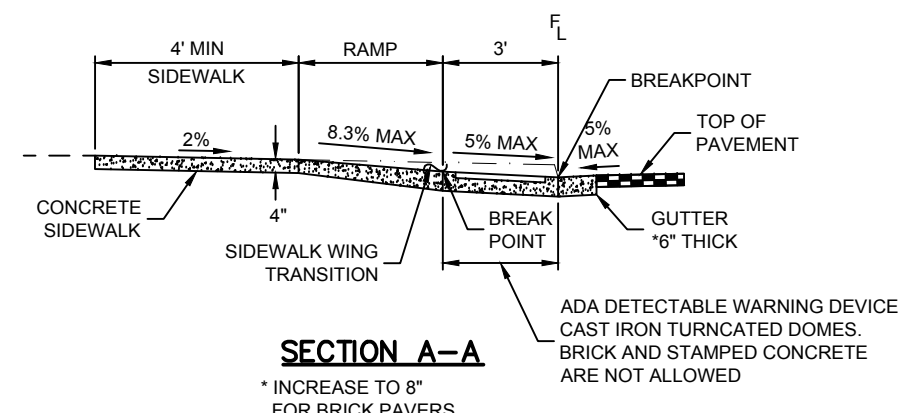

SECTION A-A
* INCREASE TO 8" FOR BRICK PAVERS.

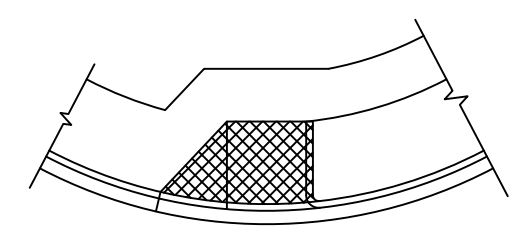

RAMP PAY AREA
FOR CURB RAMPS TYPE 4A AND 4B

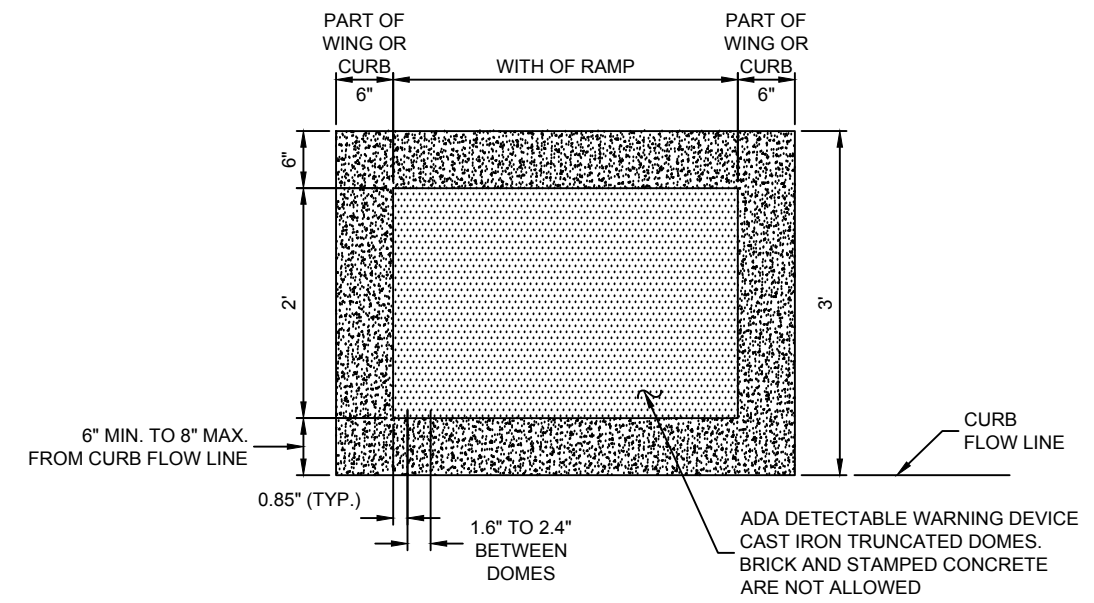

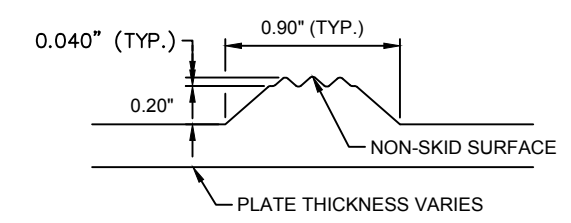

PLAN VIEW OF DETECTABLE WARNING PLATE
FOR CURB RAMPS

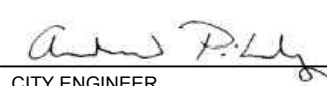

ELEVATION VIEW OF DETECTABLE WARNING PLATE
FOR CURB RAMPS

C:\Division Information\Engineering Documents\Engineering and Construction\COMMERCE CITY\CAD Files\2016 Updated Files\308-03 (Curb Ramps).dwg

COMPUTER FILE INFORMATION Creation Date: 03/10/2016 Initials: CJC Last Modification Date: 5/26/2016 Initials: CJC Full Path: WWW.C3GOV.COM Drawing Name: \$FILESS\$ Scale: \$SCALESHORT\$ Units: ENGLISH		APPROVAL  CITY ENGINEER		12-15-17 DATE		 CITY OF COMMERCE CITY Department of Public Works 8602 Rosemary St. Commerce City, CO 80022 Ph: 303-289-8150		CURB RAMPS ENGINEERING CONSTRUCTION STANDARDS		DETAIL NO. 308-03d Sheet No. 4 of 4	
--	--	--	--	------------------	--	--	--	---	--	--	--

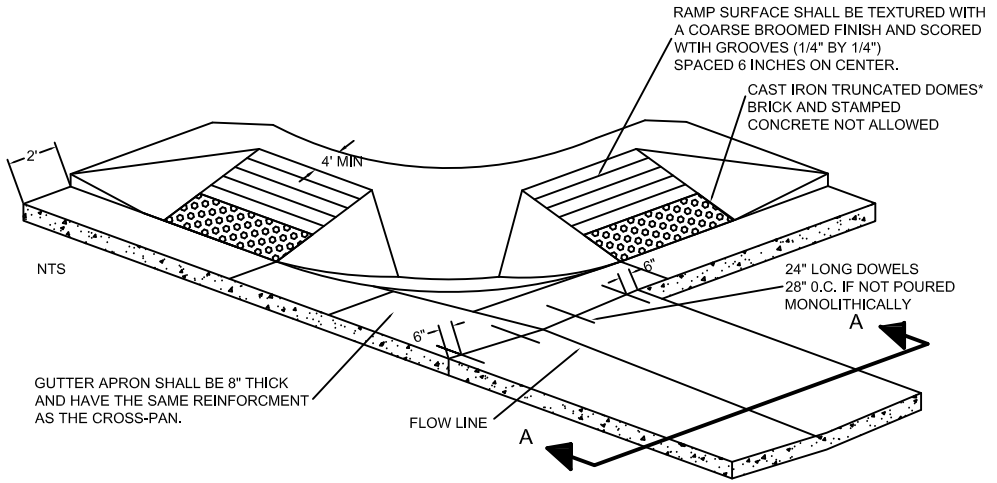

GUTTER APRON SHALL BE 8" THICK AND HAVE THE SAME REINFORCEMENT AS THE CROSS-PAN.

*MFG'S: EAST JORDAN IRON WORKS, INC. - 1-800-874-4100
NEENAH FOUNDRY CO. - 1-800-694-4660

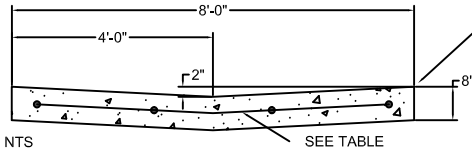

CROWN SHALL BE TRANSITIONED OUT OF THE STREET IN 50 FEET.
NO CROWN EXISTS AT THE CROSS-PAN.

SECTION A-A

NOTE:
THIS DETAIL IS GENERALIZED. ANY PARTICULAR INSTALLATION MAY INCLUDE ALL OR PART OF THE DETAIL ELEMENTS AS PART OF THE CONSTRUCTION. ANY GIVEN INSTALLATION MAY INCLUDE REQUIREMENTS OF OTHER DETAILS. EXISTING CONDITIONS AND CONFIGURATIONS OF LOCATION WILL AFFECT ACTUAL CONSTRUCTION OF RAMPS.

PAN LENGTH	WIRE MESH CALLED FOR	REPLACE WITH REBAR HAVING END AREA OF
36"	6x6 - 4,4	0.10 SQ IN PER FT
46"	6x6 - 2,2	0.13 SQ IN PER FT
64"	6x6 - 0,0	0.20 SQ IN PER FT
84"	Two 6x6 - 2,2	0.26 SQ IN PER FT

NOTE:
SQUARE RETURNS AND PANS SHALL USE WIRE MESH AS SHOWN IN THE TABLE ABOVE. WHEN WIRE MESH IS NOT AVAILABLE, STEEL REINFORCING BAR MAY BE SUBSTITUTED.

COMMERCE CITY
DEPARTMENT OF PUBLIC WORKS
ENGINEERING CONSTRUCTION STANDARDS

APPROVAL:

Andrew P. Kelly 12-15-17
CITY ENGINEER DATE

CURB RAMP WITH CROSSPAN

DETAIL NO.
308-04



ATTACHED SIDEWALK

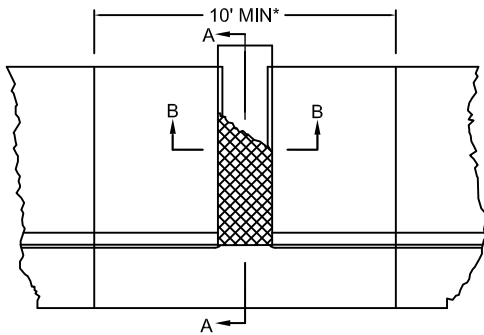

PLAN VIEW

*A MINIMUM OF 10 FEET OF NEW CONCRETE IS REQUIRED.

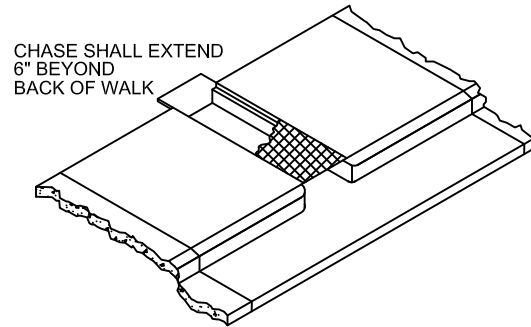

ISOMETRIC VIEW

NOTE: 1/2" EXPANSION JOINT MATERIAL REQUIRED ABUTTING EXISTING CONCRETE.

SECTION VIEWS ARE SHOWN ON DETAIL 300-19 (2)

DETACHED SIDEWALK

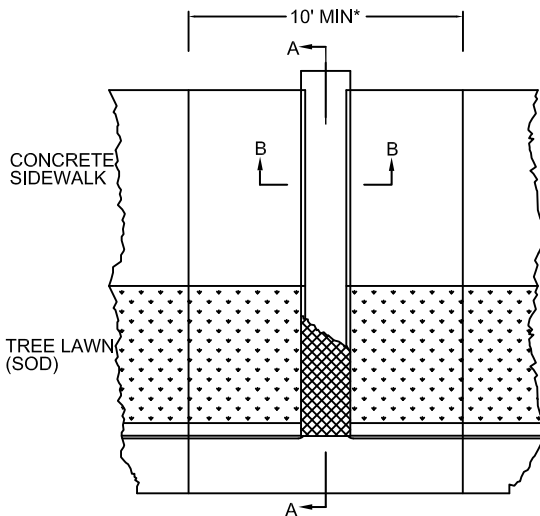

PLAN VIEW

*A MINIMUM OF 10 FEET OF NEW CONCRETE IS REQUIRED. A CONCRETE CHANNEL IS REQUIRED TO BE EXTENDED THROUGH THE TREE LAWN TO THE FLOWLINE OF THE GUTTER.

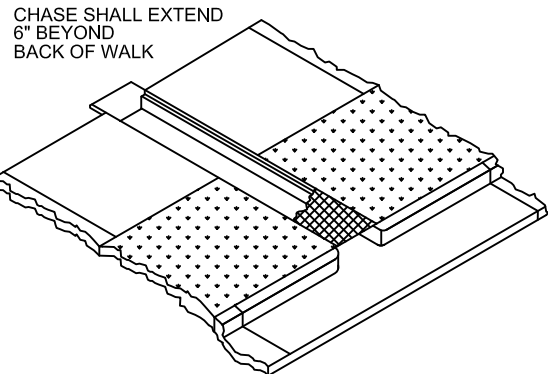

ISOMETRIC VIEW

NOTE: 1/2" EXPANSION JOINT MATERIAL REQUIRED ABUTTING EXISTING CONCRETE.

S:\Tranproj\1000-49520 - Commerce City Engineering Standards\Design\Drawings\Reference_Files\CCC DWGs\308-05 (Chase Drain).dwg

COMMERCE CITY
DEPARTMENT OF PUBLIC WORKS
ENGINEERING CONSTRUCTION STANDARDS

APPROVAL:

Maria A. Fisher

05-27-16

CITY ENGINEER

DATE

CHASE DRAIN
(1 OF 2)

DETAIL NO.
308-05



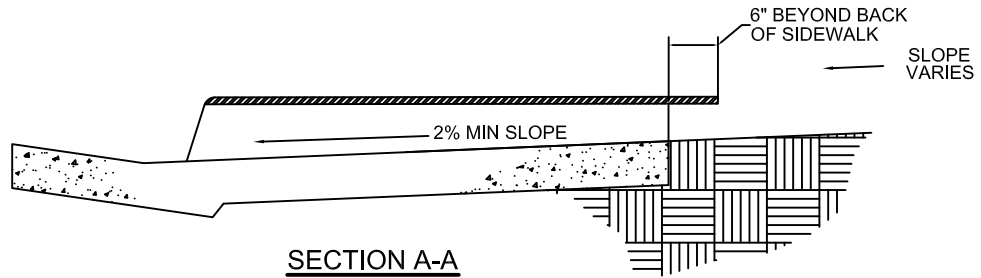

**SECTION A-A
FLOW TO GUTTER**

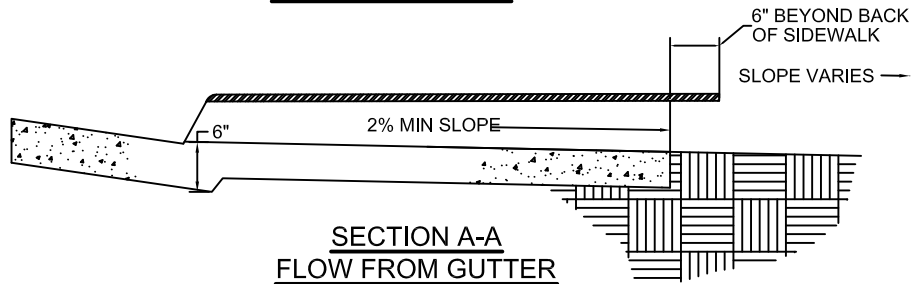

**SECTION A-A
FLOW FROM GUTTER**

SECTION B-B

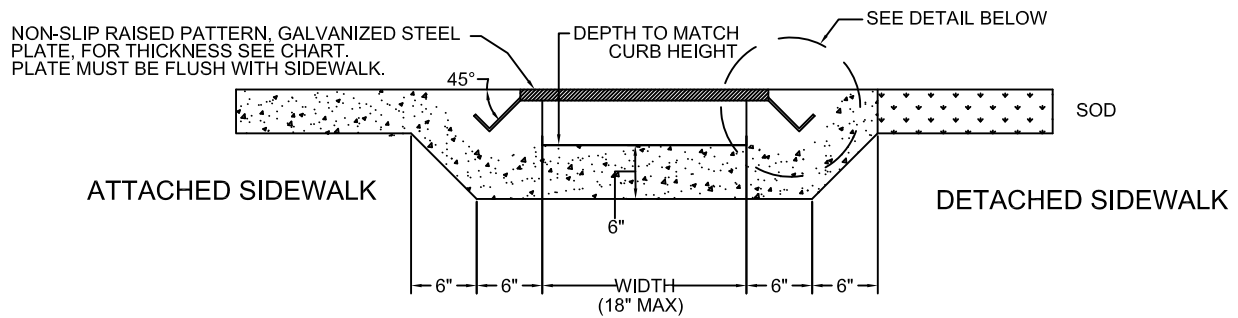

WIDTH OF OPENING	THICKNESS OF PLATE
6-12"	1/2"
12-18"	9/16"

- NOTES:**
1. 3/8" GALV. BOLT. LUBRICATE BOLT PRIOR TO SETTING PLATE.
 2. 2"x 1"x1/4" ANGLE IRON.
 3. 1/4" DIA x 3" STUDS AT 1'-0" O.C.

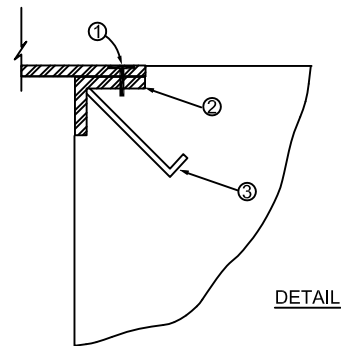

DETAIL

S:\Tranproj\1000-49520 - Commerce City Engineering Standards\Design\Drawings\Reference_Files\CCC DWGs\308-05 (Chase Drain).dwg

COMMERCE CITY
DEPARTMENT OF PUBLIC WORKS
ENGINEERING CONSTRUCTION STANDARDS

APPROVAL:
Maria A. Fisher 05-27-16
CITY ENGINEER DATE

CHASE DRAIN
(2 OF 2)

DETAIL NO.
308-05



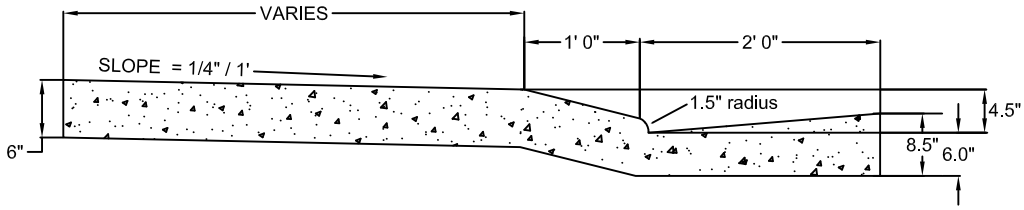

COMBINATION CURB, GUTTER AND SIDEWALK

NOT TO SCALE

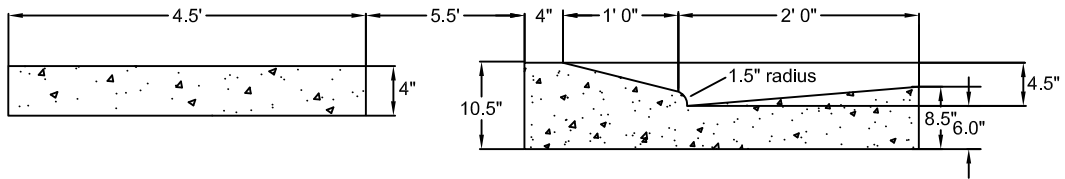

DETACHED CURB, GUTTER AND SIDEWALK

NOT TO SCALE

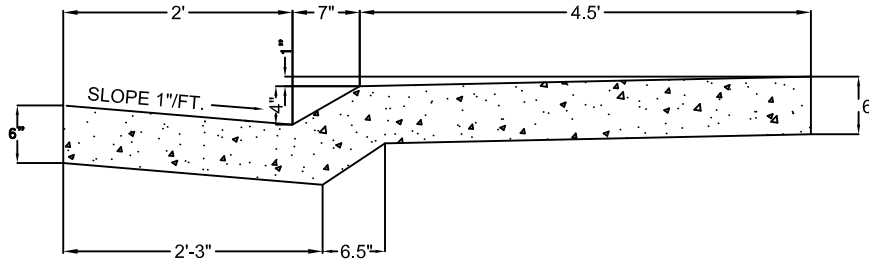

COMBINATION CURB, GUTTER AND SIDEWALK

NOT TO SCALE

S:\Tranproj\1000-49520 - Commerce City Engineering Standards\Design\Drawings\Reference_Files\CCC DWGs\308-06 (Mountable Curb Sections).dwg

COMMERCE CITY
DEPARTMENT OF PUBLIC WORKS
ENGINEERING CONSTRUCTION STANDARDS

APPROVAL:

Maria A. Fisher

CITY ENGINEER

05-27-16

DATE

MOUNTABLE CURB SECTIONS

DETAIL NO.
308-06



6" VERTICAL CURB AND GUTTER (TYPE 2)
DRAWING NOT TO SCALE

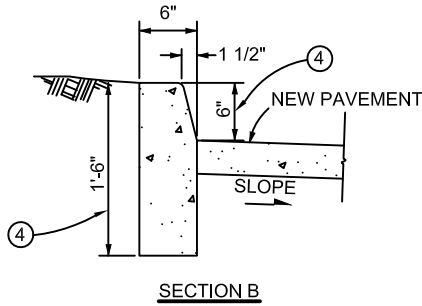
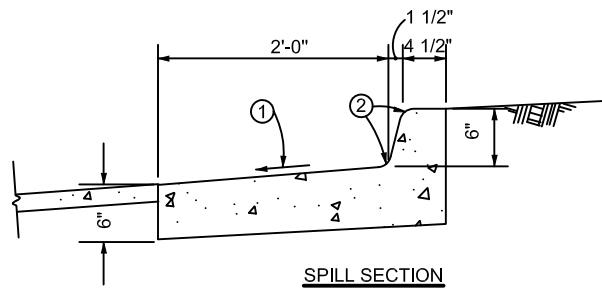
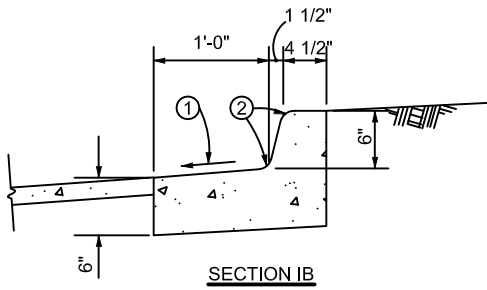
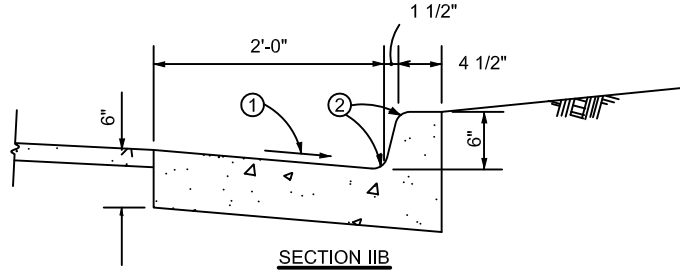

NOTES:

1. GUTTER CROSS SLOPES SHALL BE 1/2" / FT WHEN DRAINING AWAY FROM CURB AND 1" / FT WHEN DRAINING TOWARD CURB
2. 1 1/2" RADIUS TYPICAL
3. 3/4" Ø x 12" DEFORMED REINFORCING BARS AT 6 FT. SPACING. BARS TO BE GROUTED IN 1-1/2" Ø HOLES IN EXISTING CONCRETE. GROUT TO CONSIST OF 2 PARTS CLEAN SAND AND 1 PART CEMENT.
4. 9" CURB HEIGHT, 1'-9" OVERALL HEIGHT FOR MEDIAN.

COMMERCE CITY
DEPARTMENT OF PUBLIC WORKS
ENGINEERING CONSTRUCTION STANDARDS

APPROVAL:

Maria Q. Fisher

CITY ENGINEER

05-27-16

DATE

VERTICAL CURB SECTIONS

DETAIL NO.
308-07



EXPANSION JOINT

N.T.S.

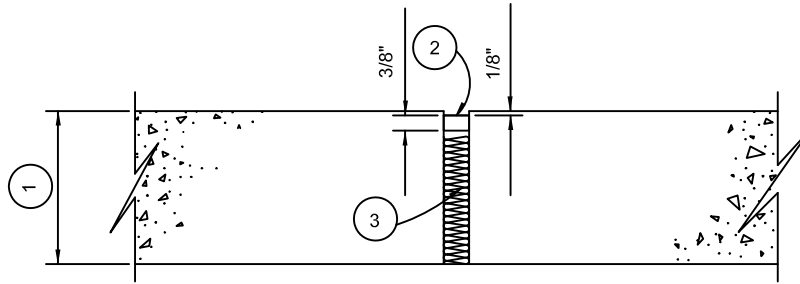

NOTES:

1. (T) THICKNESS OF PAVEMENT, SEE TYPICAL PAVEMENT SECTION.
2. POURED JOINT MATERIAL.
3. 1/2" PREFORMED JOINT MATERIAL. INSTALL EXPANSION JOINT MATERIAL BETWEEN NEW SIDEWALK AND EXISTING CONCRETE SLABS, POLES, FIRE HYDRANTS, BUILDINGS, ETC. SET EXPANSION JOINT MATERIAL VERTICAL AND WITH THE TOP EDGE BELOW FINISHED SURFACE OF CONCRETE. PROVIDE EXPANSION JOINTS EVERY 100' TO 120'.

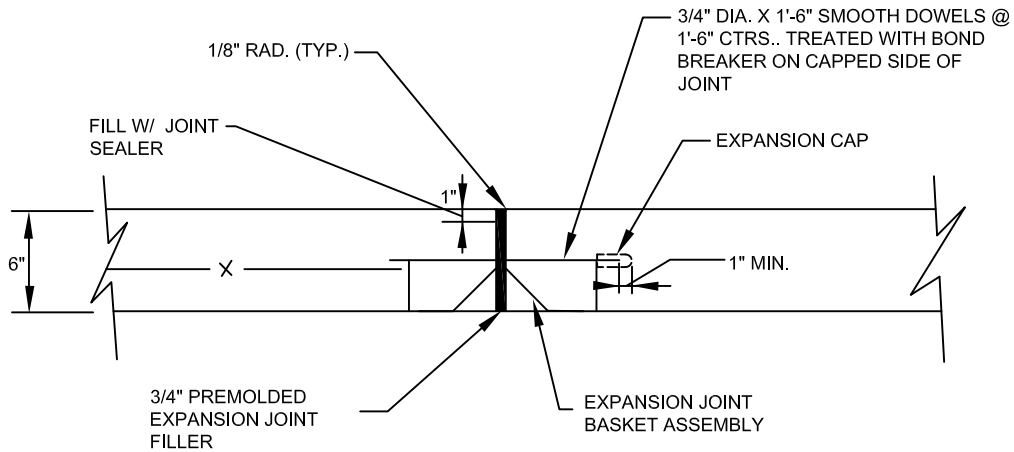

SECTION

NOTE:
THIS DETAIL DOES NOT APPLY TO EXPANSION JOINT WHERE PAVEMENT ABUTS A STRUCTURE. USE ONLY JOINT FILLER AGAINST STRUCTURE.

S:\Tranproj\1000-49520 - Commerce City Engineering Standards\Design\Drawings\Reference_Files\CCC DWGs\308-08 (Expansion_Joint_Details).dwg

**COMMERCE CITY
DEPARTMENT OF PUBLIC WORKS
ENGINEERING CONSTRUCTION STANDARDS**

APPROVAL:
CITY ENGINEER 05-27-16
DATE



EXPANSION JOINT DETAILS

DETAIL NO.
308-08

CONTRACTION JOINT

N.T.S.

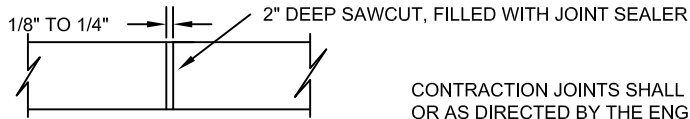

CONTRACTION JOINTS SHALL BE PLACED EVERY 10 FEET OR AS DIRECTED BY THE ENGINEER.

ALTERNATE TRANSVERSE CONTRACTION JOINT

N.T.S.

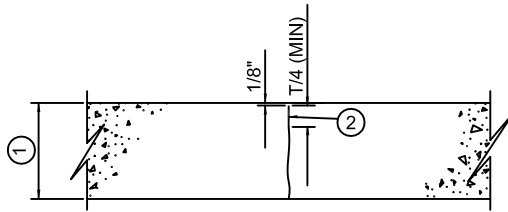

- NOTES:
- (T) THICKNESS OF PAVEMENT, SEE TYPICAL PAVEMENT SECTION.
 - 20 MILL POLYURETHANE PLASTIC PARTING STRIP. SPLICE WITH ENDS BUTTED.

CONTRACTION JOINT

N.T.S.

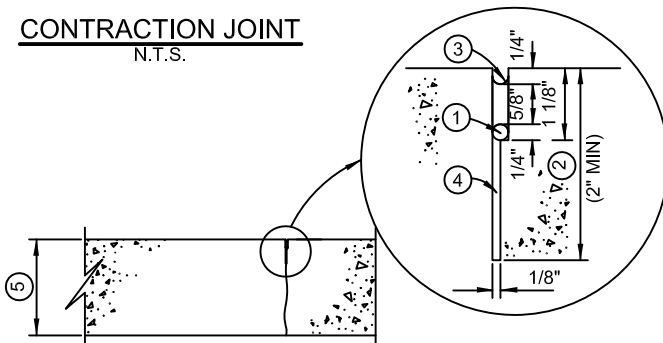

- NOTES:
- BACKER ROD OF OPEN OR CLOSED CELL POLYURETHANE STRAND AS APPROVED.
 - T/4+1/2" LONGITUDINAL, T/4 TRANSVERSE. MAY BE 1/4" SAWCUT FOR ITS FULL DEPTH WITH JOINT MATERIAL AND BACKER ROD AT SAME DEPTH.
 - POURED JOINT MATERIAL.
 - AIR
 - (T) THICKNESS OF PAVEMENT, SEE TYPICAL PAVEMENT SECTION.

S:\Tranproj\1000-49520 - Commerce City Engineering Standards\Design\Drawings\Reference_Files\CCC DWGs\308-09 (Contraction Joint Details).dwg

COMMERCE CITY
DEPARTMENT OF PUBLIC WORKS
ENGINEERING CONSTRUCTION STANDARDS

APPROVAL:

Maria A. Fisher

05-27-16

CITY ENGINEER

DATE

CONTRACTION JOINT DETAILS

DETAIL NO.
308-09



S:\Training\100049520 - Commerce City Engineering Standards\Design Drawings\Reference_Files\CCC DWGs\308-10 (Curb Detail with Sump Pipe).dwg

GENERAL NOTES

1. MINIMUM SIDEWALK WIDTH IS 4.5 FT FOR DETACHED SIDEWALK, OR MATCH EXISTING. CORE CITY IS 3' AND 4' - NORTHERN RANGE MINIMUM IS 4.5.
2. REMOVE/REPLACE CURB AND GUTTER AND/OR SIDEWALK TO NEAREST EXISTING JOINT LINE.
3. MAINTAIN 5' MINIMUM OVERALL LENGTH WHEN REPLACING EXISTING CURB & GUTTER AND/OR SIDEWALK.
4. PIPE MATERIAL IS SCH 40 PVC.

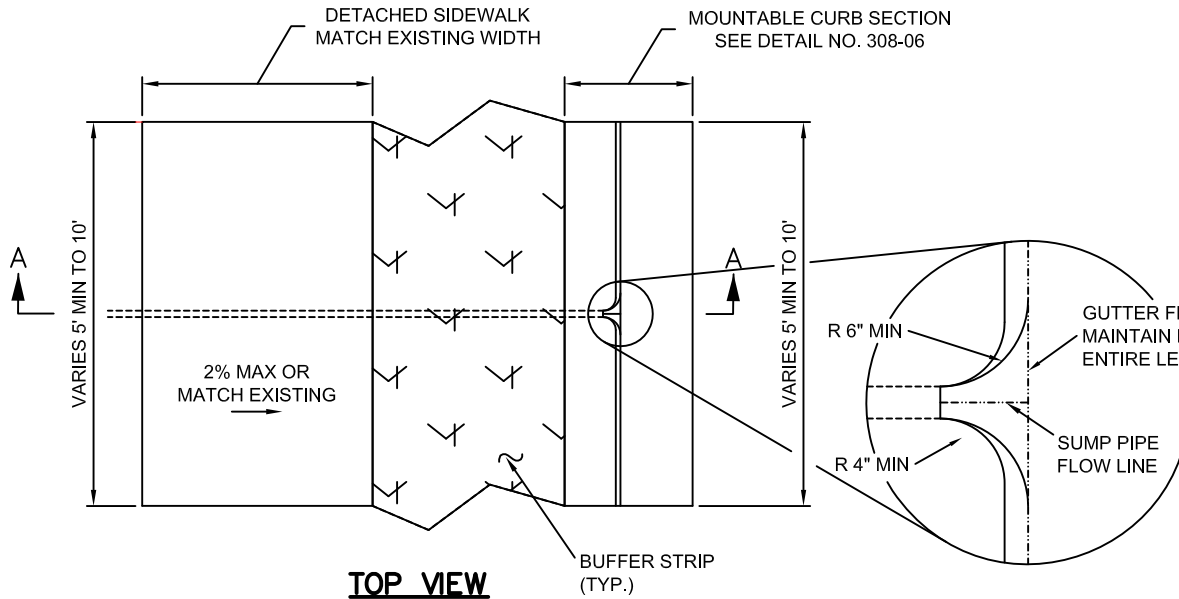

TOP VIEW

SHOWN WITH DETACHED SIDEWALK

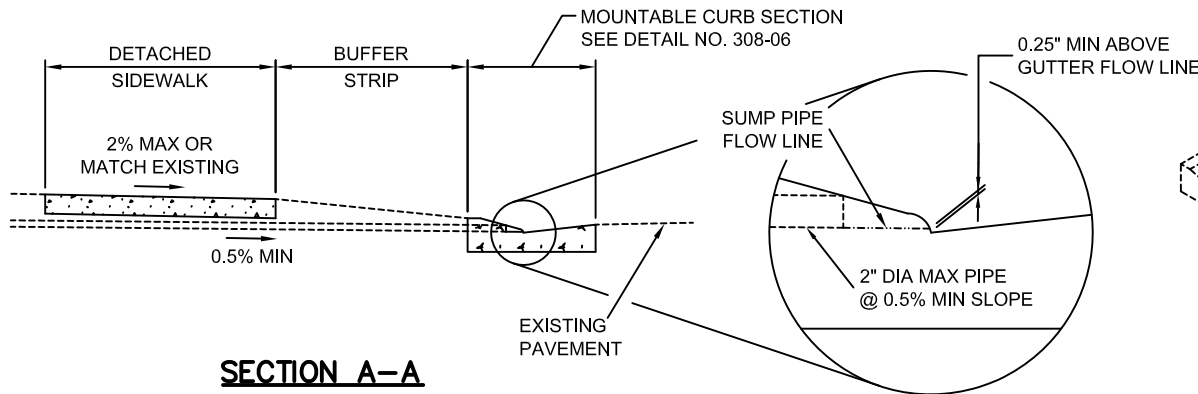

SECTION A-A

SHOWN WITH DETACHED SIDEWALK

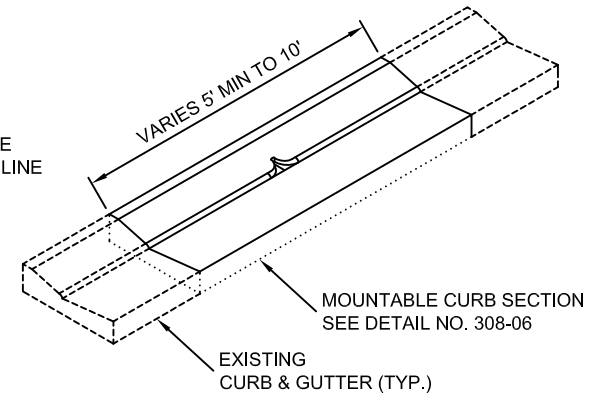

ISOMETRIC VIEW

SHOWN WITH MOUNTABLE CURB

COMMERCE CITY
DEPARTMENT OF PUBLIC WORKS
ENGINEERING CONSTRUCTION STANDARDS

APPROVAL:

Maria A. Fisher

05-27-16

CITY ENGINEER

DATE

CURB DETAIL WITH SUMP PIPE

DETAIL NO.

308-10



S:\Trainproj\100049520 - Commerce City Engineering Standards\Design\Drawings\Reference_Files\CCC DWG\311-01 (Survey Monuments).dwg

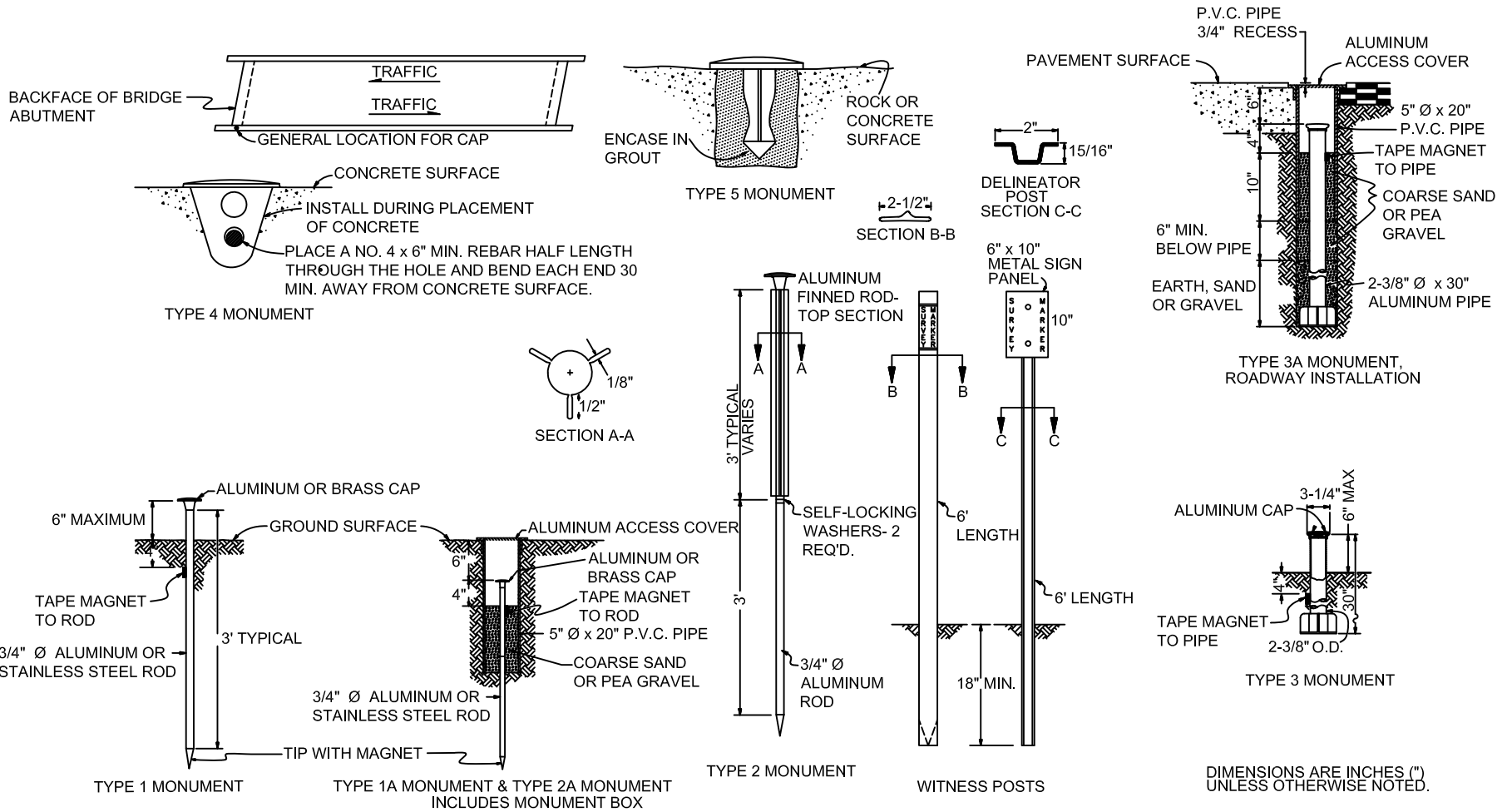

COMMERCE CITY
 DEPARTMENT OF PUBLIC WORKS
 ENGINEERING CONSTRUCTION STANDARDS

APPROVAL:
Maria A. Fisher
 CITY ENGINEER
 05-27-16
 DATE

SURVEY MONUMENTS

DETAIL NO.
 311-01



S:\Trainproj\100049520 - Commerce City Engineering Standards\Design Drawings\Reference_Files\CCC DWG\311-02 (Screw Type Adjustable Monument Box).dwg

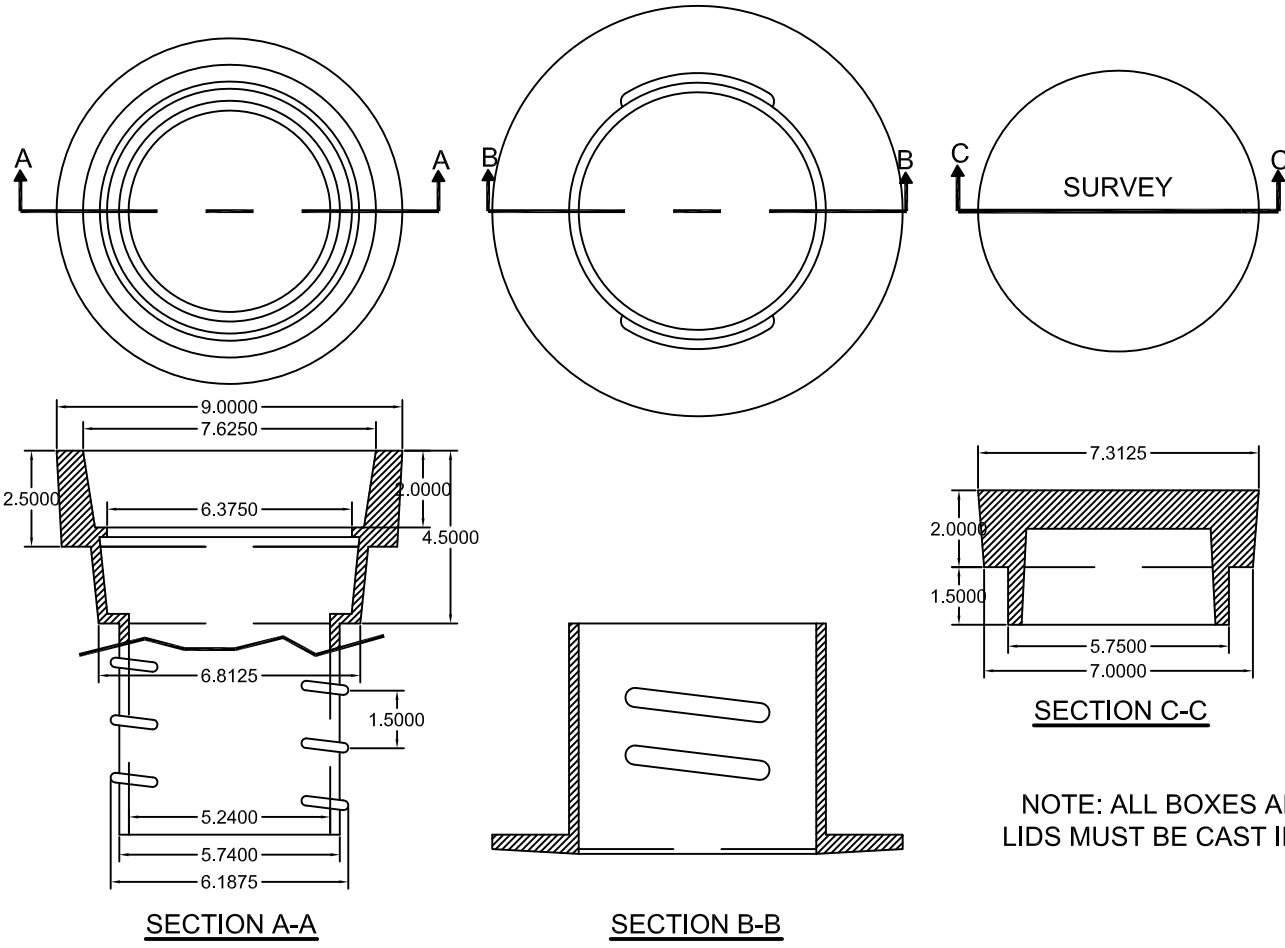

NOTE: ALL BOXES AND LIDS MUST BE CAST IRON

COMMERCE CITY
DEPARTMENT OF PUBLIC WORKS
ENGINEERING CONSTRUCTION STANDARDS

APPROVAL:
Maria A. Fisher 05-27-16
CITY ENGINEER DATE

SCREW TYPE ADJUSTABLE
MONUMENT BOX

DETAIL NO.
311-02



S:\Tranproj\1000-49520 - Commerce City Engineering Standards\Design\Drawings\Reference_Files\CCC DWGs\312-01 (Typical Utility Locations).dwg

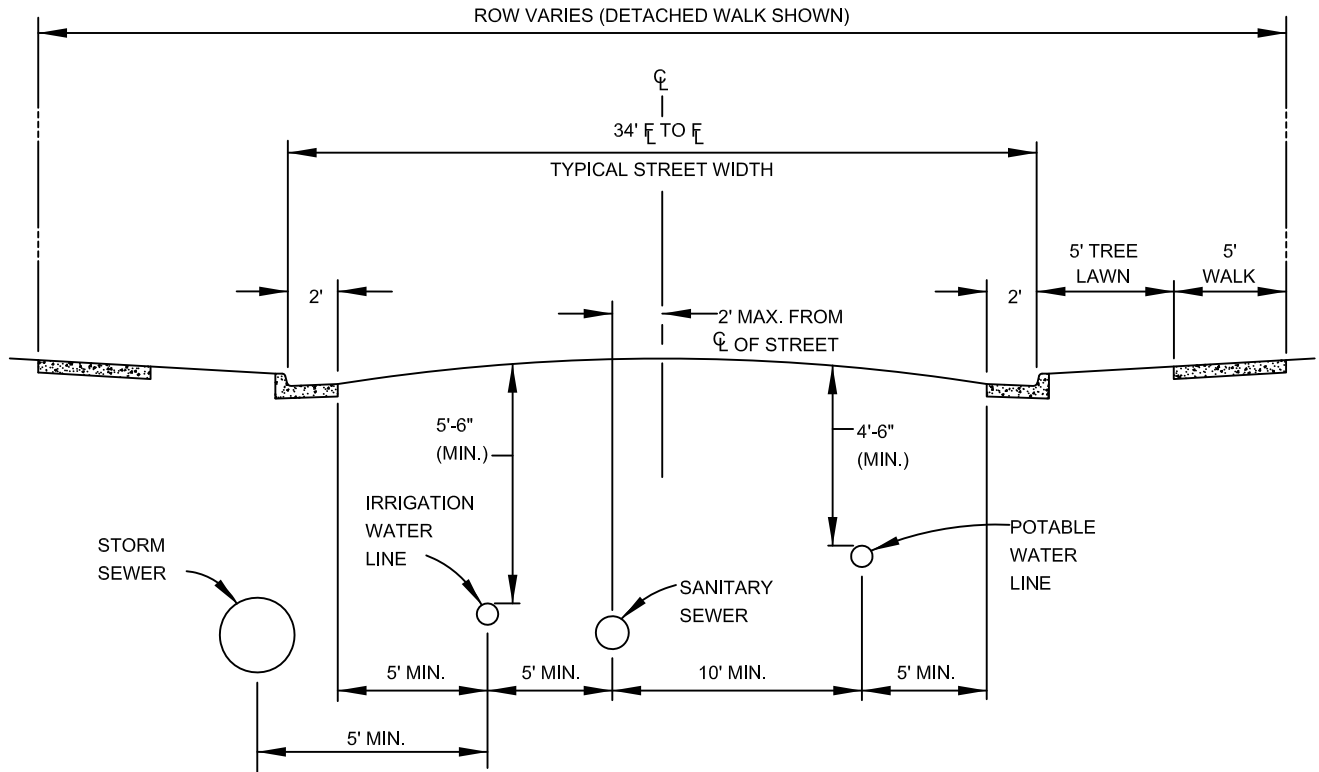

COMMERCE CITY
DEPARTMENT OF PUBLIC WORKS
ENGINEERING CONSTRUCTION STANDARDS

APPROVAL:

Maria A. Fisher

05-27-16

CITY ENGINEER

DATE

TYPICAL UTILITY LOCATIONS

DETAIL NO.
312-01



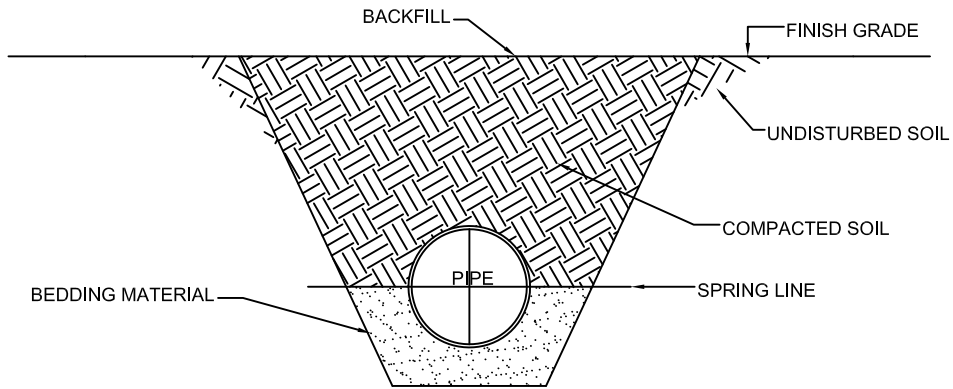

REINFORCED CONCRETE PIPE

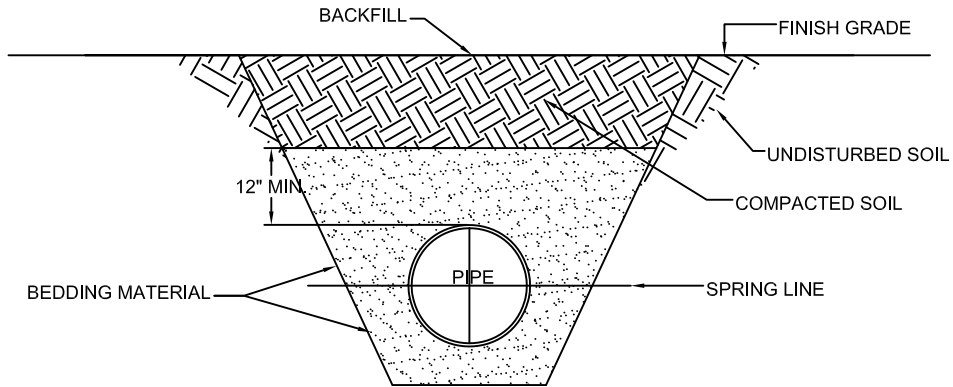

P.V.C PIPE & DUCTILE IRON PIPE

NOTE:

FOR SOILS WITH 50% OR MORE BY WEIGHT RETAINED ON THE #40 SIEVE
 BEDDING SHALL BE CDOT CLASS A FILTER MATERIAL (ASTM C-33 NO. 67 AGGREGATE
 GRADATION) OR EQUIVALENT
 FOR SOILS WITH LESS THAN 50% BY WEIGHT RETAINED ON THE #40 SIEVE
 BEDDING SHALL BE CDOT CONCRETE SAND, AASHTO M6 BEDDING, OR EQUIVALENT

S:\Tranproj\1000-49520 - Commerce City Engineering Standards\Design\Drawings\Reference_Files\CCC DWGs\312-02 (Pipe Stabilization).dwg

COMMERCE CITY
 DEPARTMENT OF PUBLIC WORKS
 ENGINEERING CONSTRUCTION STANDARDS

APPROVAL:

 CITY ENGINEER
 05-27-16
 DATE



PIPE STABILIZATION

DETAIL NO.
 312-02

- FM** DOWELED LONGITUDINAL CONSTRUCTION JOINT
- DC** DOWELED TRANSVERSE CONTRACTION JOINT
CDOT DETAIL M-412-1
- E** LONGITUDINAL CONTRACTION OR CONSTRUCTION JOINT
CDOT DETAIL M-412-1

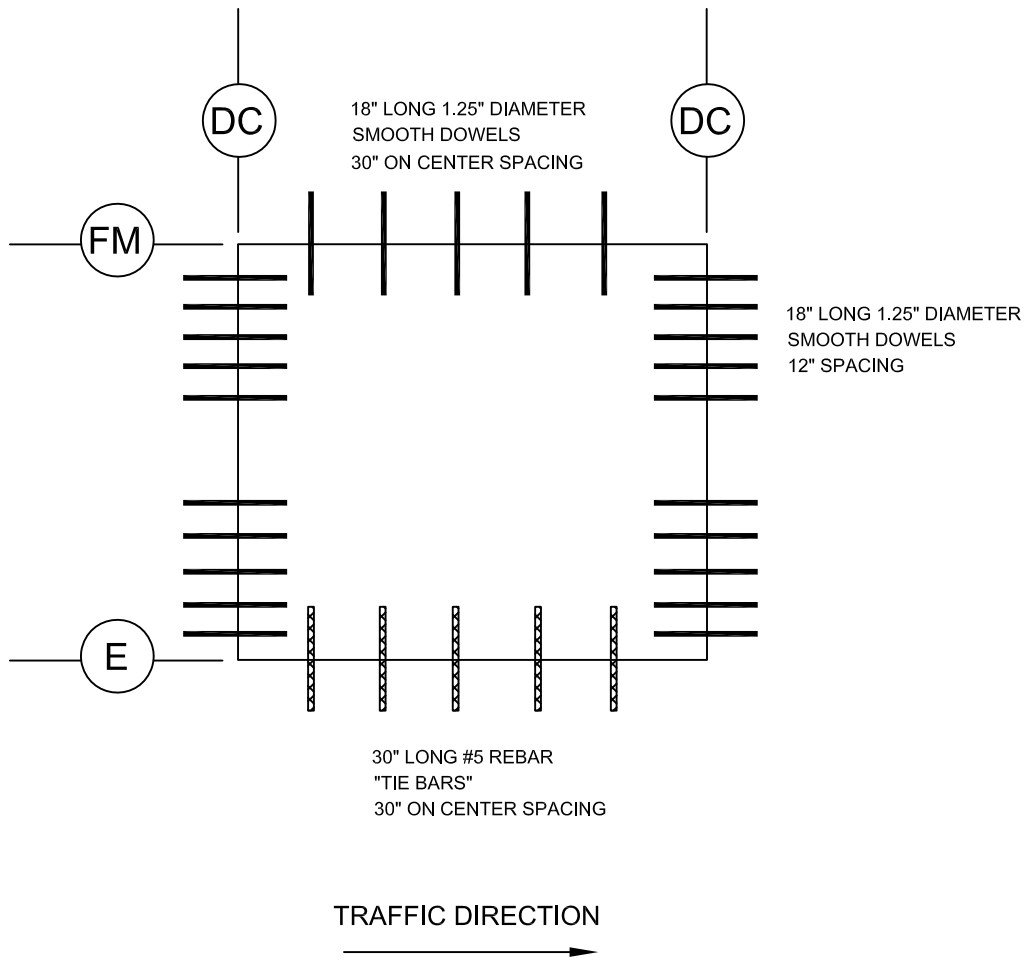

S:\Tranproj\1000-49520 - Commerce City Engineering Standards\Design\Drawings\Reference_Files\CCC DWGs\399-01 (Concrete Panel Replacement).dwg

<p>COMMERCE CITY DEPARTMENT OF PUBLIC WORKS ENGINEERING CONSTRUCTION STANDARDS</p>	<p>APPROVAL: <i>Maria A. Fisher</i> CITY ENGINEER 05-27-16 DATE</p>	
<p>CONCRETE PANEL REPLACEMENT</p>	<p>DETAIL NO. 399-01</p>	