

*Commerce City, Colorado*

# Typical Basement Finish Details

Based on the 2018 International Residential Code



The design details in this document apply to residential basement finishes only. Construction cannot deviate from the details herein unless prior approval is obtained by the city. A copy of this document must be on the job site and available during each required inspection.



Commerce City, Colorado  
**Typical Basement Finish Details**

**CONTENTS**

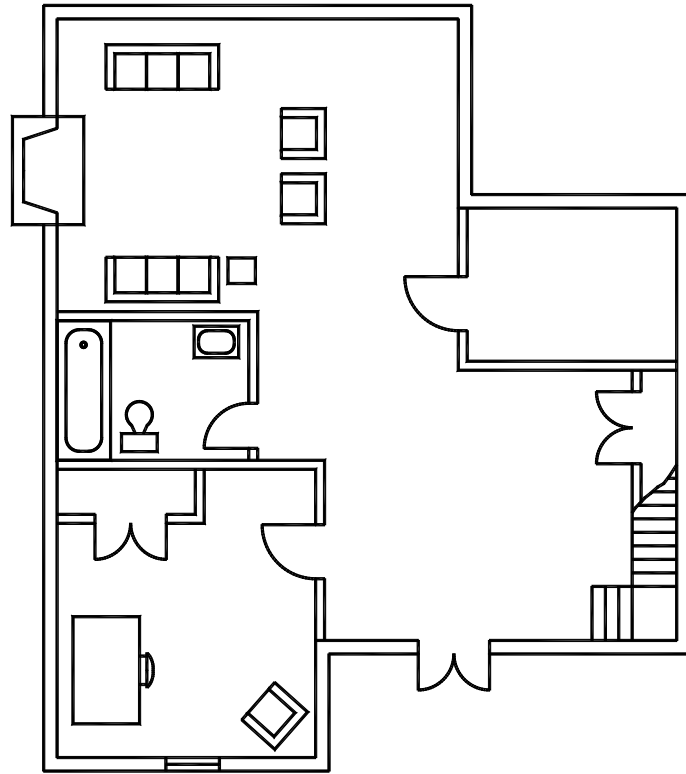

**Section 1** ■ General Notes .....3  
**Section 2** ■ Emergency Escape and Rescue .....3  
**Section 3** ■ Partition Construction .....5  
**Section 4** ■ Drilling and Notching.....8  
**Section 5** ■ Floor/ceiling Construction .....8  
**Section 6** ■ Mechanical, Plumbing & Electrical.....9

## Section 1 ▪ General Notes

These typical basement finish details are provided to ensure design and construction of basements in Commerce City is consistent and code compliant. Prior to designing your basement finish, read this publication thoroughly and pay close attention to each applicable detail.

### DESIGN CONSIDERATIONS

1. Habitable rooms (excluding closets, hallways, laundry rooms, storage spaces and bathrooms) shall have an area of not less than 70 square feet and shall not be less than 7 feet in any direction.
2. Hallways shall not be less than 36 inches in width.
3. Basement ceiling height shall not be less than 7 feet above the finished floor. Beams, girders, ducts or other obstructions may project to within 6 feet 4 inches of the finished floor.
4. Bathrooms shall be equipped with a fan vented directly to the outside. A fan is not required if the bathroom contains a window with an opening of 1.5 square feet or more.
5. Space under stairs shall be protected with ½-inch drywall on the underside or with a non-accessible enclosure clad in ½-inch drywall.
6. A smoke alarm shall be installed in the basement, on each floor of the house, in each bedroom of the house and outside each sleeping areas in the immediate vicinity of bedrooms. Smoke alarms shall not be installed less than 3 feet from doorways to bathrooms with tubs or showers.
7. If the house is equipped with gas-fired appliances, carbon monoxide alarms shall be installed within 15 feet of the appliances and on every floor.
8. Smoke alarms shall be interconnected such that when one is activated, all will sound. Likewise, carbon monoxide alarms shall also be interconnected.
9. Smoke alarms and carbon monoxide alarms in the basement shall be hardwired with a battery backup. All other alarms are permitted to be battery-operated only.
10. All basement stairs shall have a light source to illuminate all treads and landings. Lights shall be operated by a switch located at the top and bottom of the stairs.
11. Basement walls should be insulated with continuous R-15 or, when installed between studs, insulation should be R-19. If opting to install R-19, studs must be a minimum of 2x6.
12. Basement finishes that include a kitchen, wet bar or bedroom require a plan submission and approval by the city.
13. Cutting openings in existing basement walls requires a plan submission.
14. Deviations from these details require approval by city staff prior to construction.

If you have questions, please contact the city at **303-289-3790, TTY 711** or via email at [cdpermits@c3gov.com](mailto:cdpermits@c3gov.com). For information regarding permit application and inspections, go to [c3gov.com/buildingpermits](http://c3gov.com/buildingpermits).

## Section 2 ▪ Emergency Escape and Rescue

**Where required.** An emergency escape and rescue opening (EERO) in the form of a window or door to the outside is required in basements of houses constructed after October 1, 2003 and all basement bedrooms regardless of when they are constructed. An EERO in a bedroom may serve the entire basement. Basements in houses constructed prior to October 1, 2003 are permitted to be finished without an EERO; however, it is strongly recommended you provide one.

**EERO options.** Openings can be used for emergency escape and rescue are permitted to be a window or door in a walk-out basement condition, a window or door to a window well or areaway, or a door to bulkhead enclosure (Bilco door or similar).

**Opening requirements.** The emergency escape and rescue opening shall meet the requirements below.

- See for typical window opening requirements.
- All doors and windows must be operable from the inside without the need of a key or tool.

**Window well requirements.** When grade conditions require the sill of the window to be below the outside grade elevation, then a window well must be constructed. The minimum required horizontal clear floor area of a new window well is 9 square feet as measured when the window is in the open position (this is important when the window is a casement/crank-out type). See FIGURE 2 and FIGURE 3. Existing window wells with a horizontal clear floor area of 8 square feet and the minimum dimensions noted in the footnotes of FIGURE 2 and FIGURE 3 are permitted to serve a basement EERO.

**New window well construction.** A plan submission to the city is required for the construction of a new window well. If you choose to use a prefabricated window well, you must submit the manufacturer's specification during the permit application process.

**Drainage.** Window wells shall drain into the existing foundation drainage system or to daylight. If there is no existing drainage system, the area below the window well shall be filled with Number 57 stone from the elevation of the bottom of the existing foundation wall footing to the underside of the new window well.

**Ladder requirements.** When a new or existing window well is deeper than 44 inches, a permanent, attached ladder or steps must be provided per FIGURE 2. If the ladder projects more than 6 inches into the required horizontal area, the size of the window well must be increased to compensate.

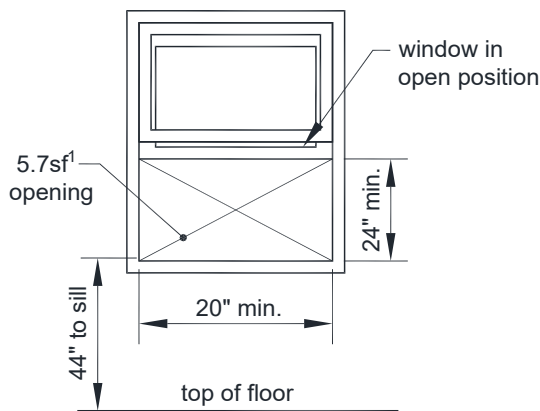

<sup>1</sup> Window openings to a walk-out condition are permitted to have a 5.0 sf opening.

**FIGURE 1: EERO REQUIREMENTS**

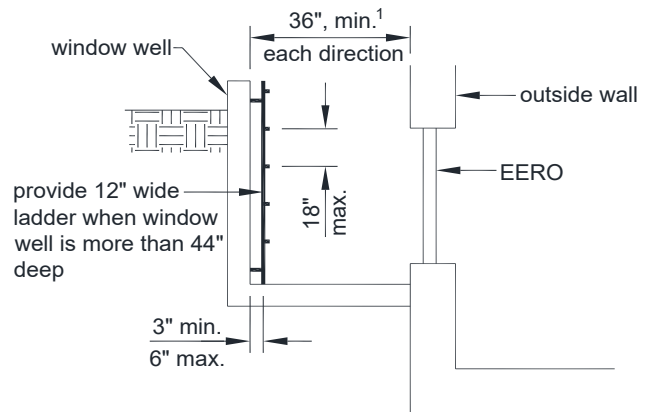

<sup>1</sup> Existing window wells are permitted to be 24" minimum perpendicular to the outside wall.

**FIGURE 2: WINDOW WELL REQUIREMENTS**

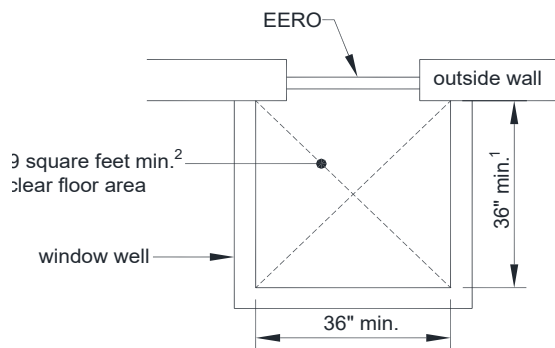

**AT DOUBLE-HUNG OR SLIDING WINDOW**

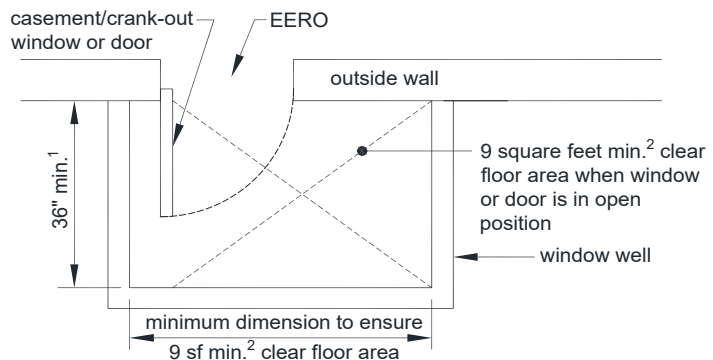

**AT CASEMENT/CRANK-OUT WINDOW**

<sup>1</sup> Existing window wells are permitted to be 24" minimum perpendicular to the outside wall provided the clear floor area is a minimum of 8 square feet.

<sup>2</sup> Existing window wells are permitted to have a minimum clear floor area of 8 square feet.

**FIGURE 3: CLEAR FLOOR AREA**

## Section 3 ■ Partition Construction

**Studs.** Studs may be 2x4 or 2x6 utility grade or better. Partitions shall have a single preservative-treated bottom plate or floor plate associated with a floating partition and can have a single or double top plate. Studs shall be placed at 16 inches on center, but may be increased to a 24 inches on center when applied finish material is drywall.

**Headers.** A single flat 2x4 may be used as a header in non-load bearing partitions for openings up to 8 feet in width if the portion of the partition above the opening is not more than 24 inches in height. If the opening does not meet these conditions, the header shall be framed per FIGURE 4 and sized per TABLE 1. Two-ply headers shall be fastened together using 16d common (3½" x 0.162") face nails at 16 inches on center, or 16d box (3½" x 0.135") face nails at 12 inches on center, staggered along the top and bottom edges.

**TABLE 1: HEADER SIZE**

HEADER SIZE	SPAN LENGTH, FEET
(2)2x4	4
(2)2x6	6
(2)2x8	10
(2)2x10	12
(2)2x12	16

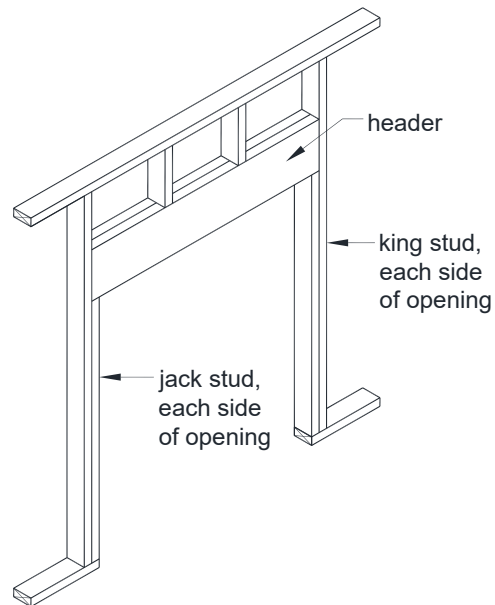

**FIGURE 4: FRAMING AT HEADERS**

**Attachment requirements.** Partition construction shall be fastened in accordance with TABLE 2.

**TABLE 2: FASTENING SCHEDULE**

CONNECTION	NAILING METHOD	FASTENER
Top plate, bottom plate <sup>1</sup> or floating plate to stud	Toe nail	3-16d box (3½" x 0.135") or 4-8d box (2½" x 0.113")
	or end nail	3-16d box (3½" x 0.135") or 2-16d common (3½" x 0.162")
Bottom plate <sup>1</sup> to floor	Face nail	16d concrete nail (3½" x 0.135") @ 16" o.c.
Floating plate to top or bottom plates	Face nail	60d spikes (6" x 0.238") @ 24" o.c.
Header to jack stud (see FIGURE 4)	Toe nail	4-8d (2½" x 0.113") each side of header at each end

<sup>1</sup>Fasteners to preservative-treated plates are required to be hot-dipped galvanized.

**Fireblocking.** Fireblocking shall be provided to seal off concealed spaces and to form an effective fire barrier between stories. Fireblocking shall be provided in the following locations.

- In concealed spaces of walls and partitions, including furred spaces at the ceiling and floor level where the top plate is attached to the underside of the floor joists. See FIGURE 5.
- At all interconnections between concealed vertical and horizontal spaces such as occur at soffits, bulkheads, drop ceilings, etc. See FIGURE 6.
- In concealed spaces of stud partitions offset from the basement wall. See FIGURE 7
- In concealed spaces between stair stringers at the top and bottom of the stair run.
- At gaps and openings around vents, pipes and ducts at the ceiling and floor level.

**Fireblocking material.** Fireblocking shall consist of one of the materials listed below.

- ½-inch gypsum board.
- 2x lumber (2x4, 2x6, etc.).
- Two thicknesses of 1x lumber (1x4, 1x6, etc.) with staggered joints.
- ¾-inch plywood, OSB or particleboard with joints backed by 6 inches of the same material.
- ¼-inch cement, cement/fiber board (e.g., Durock).
- At gaps 1 inch or less, batts or blankets of mineral wool or fiberglass pack tightly to remain in-place or approved fireblocking caulk.

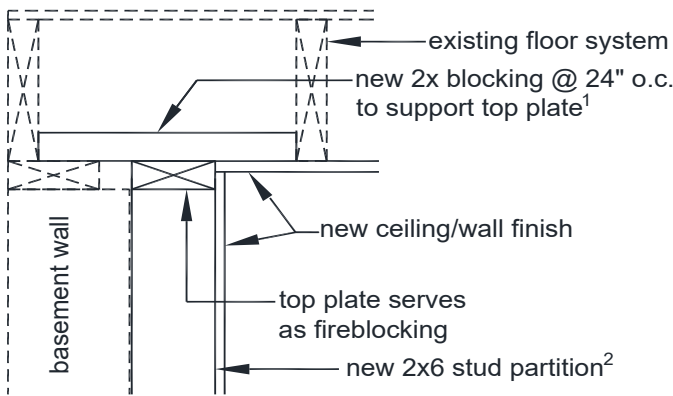

<sup>1</sup> Attach top plate to underside of joists where floor framing is perpendicular to stud partition.

<sup>2</sup> R-19 insulation should be provided between studs.

**FIGURE 5: FIREBLOCKING WITH STUD PARTITION AGAINST BASEMENT WALL**

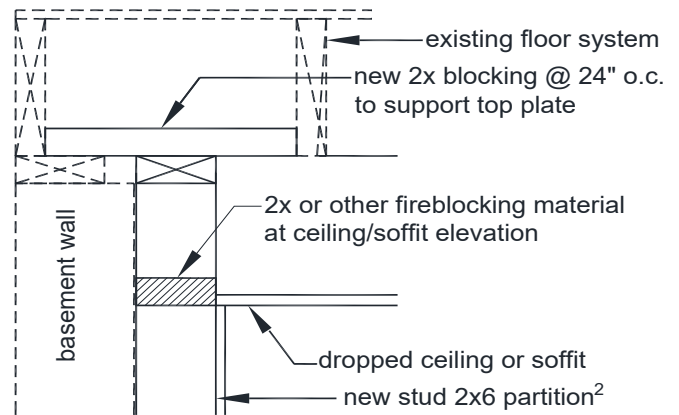

<sup>1</sup> Attach top plate to underside of joists where floor framing is perpendicular to stud partition.

<sup>2</sup> R-19 insulation should be provided between studs.

**FIGURE 6: FIREBLOCKING AT DROP CEILING**

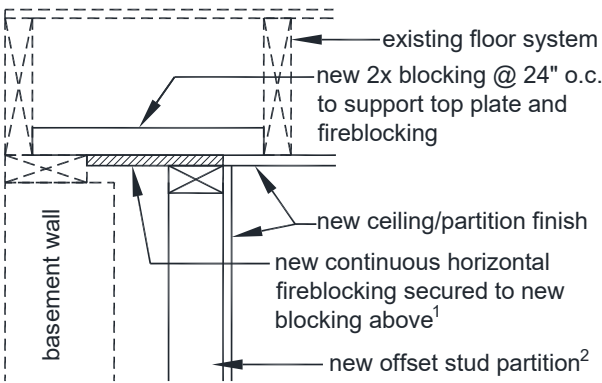

**HORIZONTAL FIREBLOCKING**

<sup>1</sup> Attach top plate and fireblocking to underside of joists where floor framing is perpendicular to stud partition.

<sup>2</sup> If cavity between basement wall and new stud partition does not contain existing insulation, then continuous R-15 insulation should be installed.

**FIGURE 7: FIREBLOCKING WITH OFFSET STUD PARTITION**

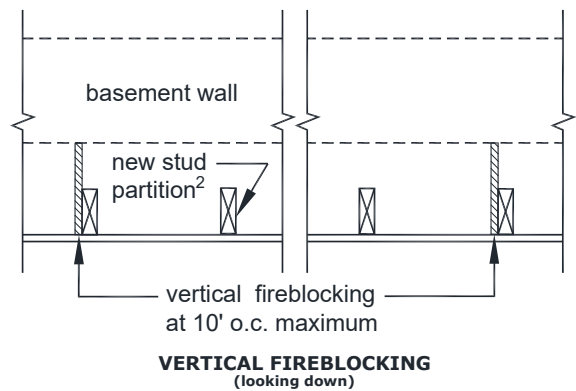

**VERTICAL FIREBLOCKING  
(looking down)**

**Floating partitions.** In areas subject to floor heaving due to expansive soils, new partitions on basement floor slabs should be built to accommodate vertical floor movement. If you do not know if your basement slab experiences heaving, it is strongly recommend you construct your partitions using the method shown in FIGURE 8 and/or FIGURE 9. Floating connections can be constructed at the bottom of the partition or at the top. To hide the required gap, baseboard molding at the bottom or top or crown molding at the top is necessary. Floating connections at the top of partitions are required for those partitions that surround shower compartments.

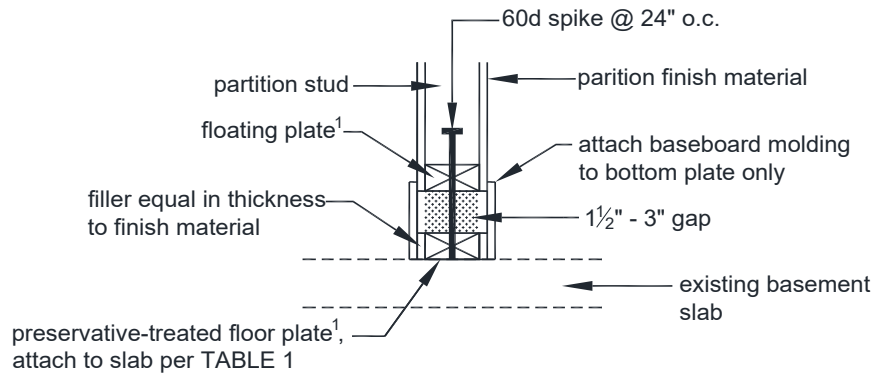

<sup>1</sup> Pre-drill plate with ¼" diameter drill bit to accommodate 60d spike.

**FIGURE 8: FLOATING PARTITION CONNECTION AT BOTTOM**

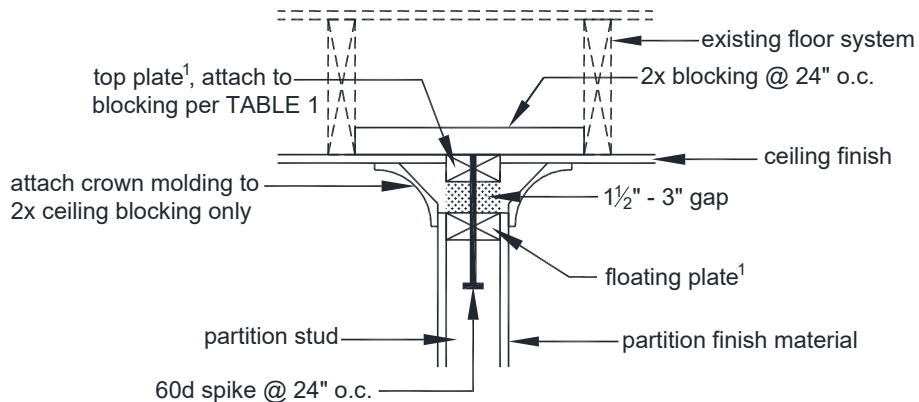

<sup>1</sup> Pre-drill plate with ¼" diameter drill bit to accommodate 60d spike.

**FIGURE 9: FLOATING PARTITION CONNECTION AT TOP**

**Interior finishes.** Partition and ceiling finish materials must meet the requirements listed below.

- Materials must have a flame spread classification no greater than 200, except for trim, molding, handrails and doors, and must have a smoke density classification no greater than 450.
- Cement or fiber-cement board (e.g., Durock) must be installed on partitions of bathtub and shower spaces and finished with a non-absorbent surface.
- Wood veneer or hardboard paneling less than ¼-inch shall not be permitted.
- Gypsum board must be ½-inch minimum.

## Section 4 ▪ Drilling and Notching

**Joists and/or beams.** Drilling and notching of wood joists and beams shall meet the requirements below.

- Drilling and notching 2x lumber shall be in conformance with FIGURE 10. Cantilevered (overhanging) joists cannot be notched.
- Drilling and notching of manufactured wood I-joists, LVL or other engineered wood product shall be per the manufacturers' instructions.
- Drilling and notching of open web floor trusses is prohibited without submitted calculations performed by a Colorado-licensed professional engineer.

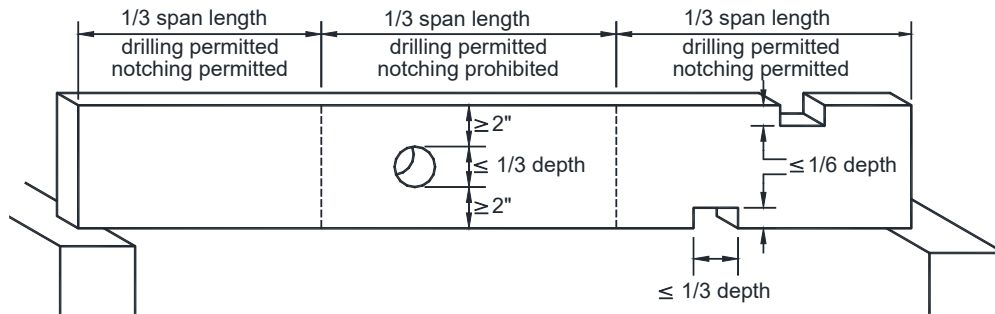

**FIGURE 10: DRILLING AND NOTCHING JOISTS**

**Studs.** Studs in interior non-loadbearing partitions may be notched or drilled in accordance with FIGURE 11.

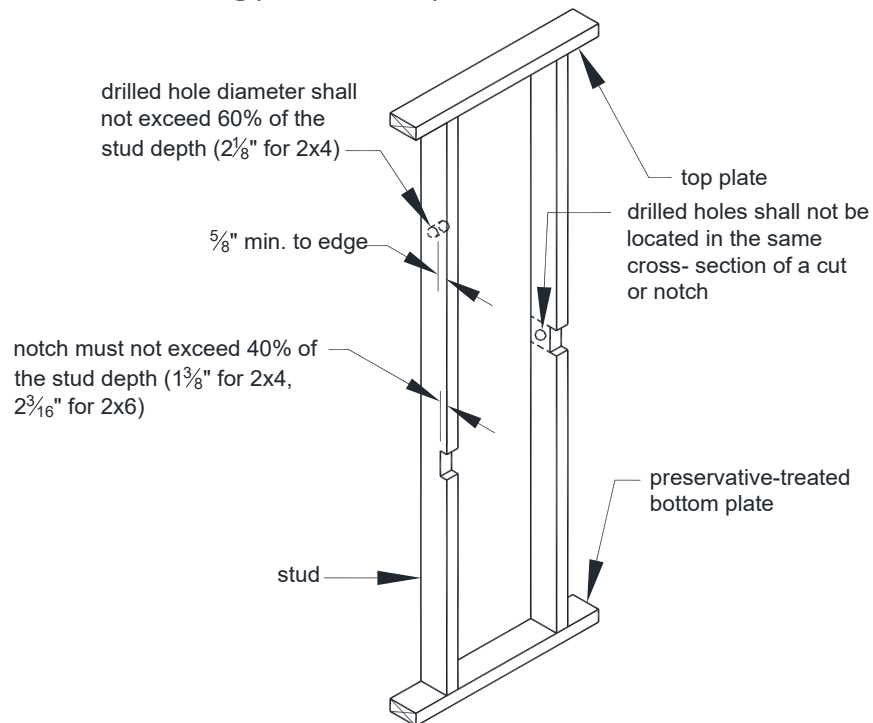
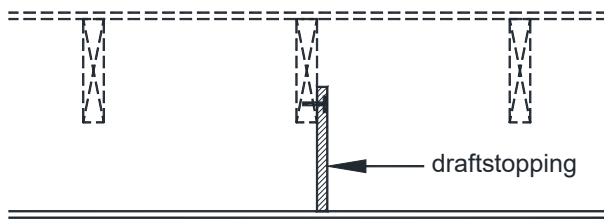

**FIGURE 11: DRILLING AND NOTCHING INTERIOR NON-LOADBEARING PARTITION STUDS**



## Section 5 ▪ Floor/Ceiling Construction

**Draftstopping.** When a ceiling is not directly attached to the underside of the floor joists above or when the floor joists are comprised of open web trusses, draftstopping must be provided. Install draftstopping to create equal-sized concealed areas not exceeding 1,000 square feet. Draftstopping shall be installed parallel to the floor framing members. See FIGURE 12 and FIGURE 13.



**FIGURE 12: DRAFTSTOPPING AT DROP CEILING**

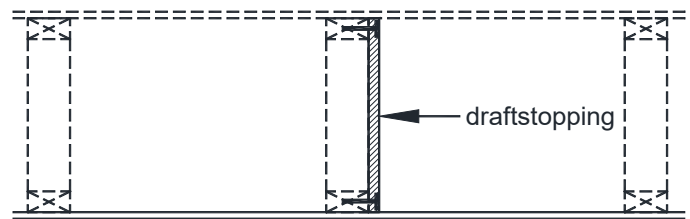

**FIGURE 13: DRAFTSTOPPING AT OPEN WEB TRUSSES**

**Draftstopping material.** Draftstopping shall consist of ½-inch minimum gypsum board, ¾-inch minimum wood plywood/OSB or ¾-inch minimum particleboard, Type 2-M-W.

## Section 6 ▪ Mechanical, Plumbing & Electrical

### MECHANICAL

**Appliance access.** Furnaces, boilers, water heaters and other appliances must be accessible without removing permanent construction and shall meet the following minimum criteria.

- 30 inches x 30 inches clear floor space at front/control side. See FIGURE 14.
- Doors to furnace rooms shall be 24 inches minimum and be of sufficient size to remove the largest appliance.

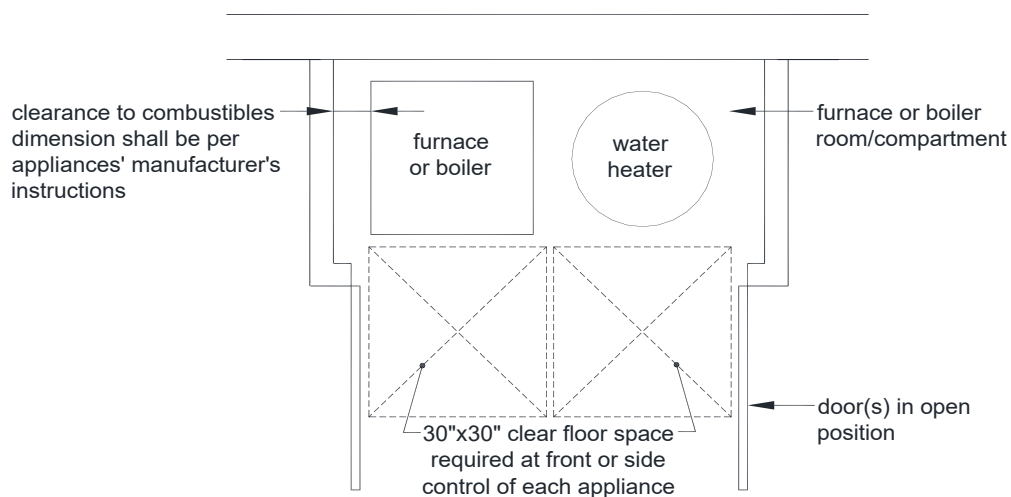

**FIGURE 14: APPLIANCE CLEARANCES**

**Combustion air.** Furnace rooms with fuel-fired appliances must be provided with two permanent openings to adjacent spaces: one within 12 inches of the top and one within 12 inches from the bottom of the adjoining wall or partition. Each opening must have a minimum free area equal to 1 square inch per 1,000 Btu per hour input rating of all appliances in the furnace room, but not less than 100 square inches. The openings are not required if a louvered door is provided or the furnace room area is greater than 50 cubic feet per 1,000 Btu per hour input rating of all appliances installed in the room.

## PLUMBING

**Showers.** Showers and shower compartments must meet the following requirements.

- Shower compartments must have a minimum total area of 900 square inches and a minimum dimension of 30 inches in any direction.
- Shower compartments may have a minimum dimension of 25 inches provided it maintains a cross sectional area of 1,300 square inches.
- Hinged shower doors must open outward.
- All glass which encloses as shower must be safety glazed.
- Shower control valves must be scald resistant (in accordance with ASSE/ANSI 1016) with a hot water limit of 120 degree F.

**Fixture clearances.** Toilets, sinks and showers shall have the minimum clearances listed below.

- 21 inches in front of sinks and toilets.
- 24 inches in front of shower stall opening.
- 4 inches between two adjacent sinks.
- 4 inches between a sink and a toilet.
- 4 inches between a sink and a wall/partition.
- 2 inches between a sink and a bathtub.
- 15 inches from a toilet's centerline to an adjacent fixture or wall/partition on each side.

**Drain size.** Fixture drain size must meet the dimensions below and must be equipped with a strainer and stopper.

**TABLE 3: MINIMUM DRAIN SIZE**

FIXTURE	DIAMETER, INCHES
Bathroom sink	1¼
Bathtubs	1½
Sinks (other than bathroom)	1½
Laundry tubs	1½
Shower	1½

**Clothes washer discharge.** The discharge of a clothes washer must be through and air break as shown in FIGURE 15.

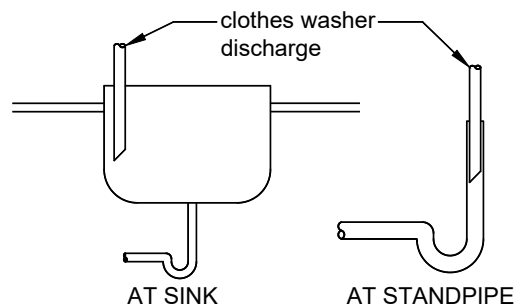

**FIGURE 15: AIRBREAK AT CLOTHES WASHER DISCHARGE**

## **ELECTRICAL**

**Panelboard (circuit breaker box).** Panel boards must meet the requirements listed below.

- A workspace 30 inches wide and 36 inches deep from floor to the ceiling with a minimum height of 6.5 feet shall be provided in front of the panel boards.
- Panel board workspace must not be used for storage at any time.
- Panel boards must not be located in clothes closets or bathrooms.
- A light shall be provided for the panel board workspace.
- Pipes or ducts cannot be located above the panelboard.

**Branch circuits.** Branch circuits must meet the requirements listed below. See TABLE 4 for more information.

- Use a 15- to 20-ampere rated branch circuit for general use purposes such as lighting and outlets.
- One “plugged-in” electrical device shall not exceed 80 percent of the circuit rating.
- Hardwired appliances or equipment may be included in a general use circuit provided its rating does not exceed 50 percent of the circuit rating.
- A dedicated 20-ampere minimum branch circuit must be provided to serve laundry room outlets only.
- A dedicated 20-ampere branch circuit must be provided to serve the bathroom receptacles.
- Branch circuits must have circuit breakers equipped as combination arc-fault/over current circuit interrupters.

**TABLE 4: BRANCH CIRCUIT REQUIREMENTS**

<b>CIRCUIT ELEMENT</b>	<b>CIRCUIT RATING</b>		
	<b>15 amp</b>	<b>20 amp</b>	<b>30 amp</b>
Minimum conductor size	14	12	10
Maximum breaker size	15	20	30
Outlets rating	15	15 or 20	30
Maximum load	15	20	30

**Lighting requirements.** Lights must meet the requirements listed below.

- At least one switched light shall be provided in each room and hallway. A switched outlet may be substituted except in bathrooms and hallways. A switched outlet cannot count towards a required outlet, see “Outlets” on Page 11.
- At least one switched or pull chain light must be provided in each storage area and at or near heating and air conditioning appliances and equipment.
- Lighting fixtures must not be installed within 3 feet horizontally and 8 feet vertically of a bathtub rim or shower stall threshold. A light fixture may be installed above a shower area if it is constructed so that water cannot enter or accumulate in wiring areas and the lighting fixture is marked “suitable for wet locations.”

**Outlets.** Outlets must meet the requirements listed below.

- Outlets shall be tamper resistant.
- Outlets shall be placed in accordance with FIGURE 16.
- The minimum wall/partition length which requires an outlet is 2 feet.
- Kneewalls, built-in bars and other fixed room dividers must be included for outlet spacing.
- Hallways more than 10 feet long must have a minimum of one outlet.
- Outlets installed for specific appliances must be within 6 feet of the appliance location.
- Bathrooms must have at least one outlet located on a wall/partition adjacent to each basin and within 36 inches of the bathroom sink. All bathroom outlets must have ground fault circuit interrupter (GFCI) protection.

- At least one outlet must be provided to serve laundry appliances and sinks.
- Each unfinished portion of the basement is required to have at least one outlet that is GFCI protected.
- An outlet must be provided within 25 feet of heating and air conditioning appliances and equipment.

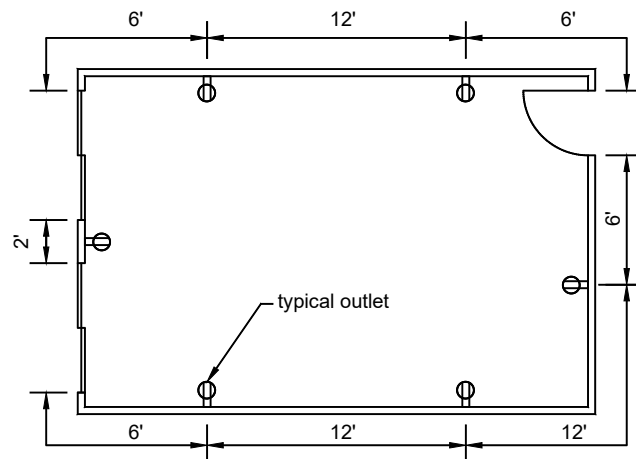

**FIGURE 16: TYPICAL OUTLET DISTRIBUTION**

**Light fixtures in closets.** Fixtures installed in clothes closets shall be limited surface or recess mounted, incandescent or LED fixtures with completely enclosed lamps, surface mounted or recessed fluorescent fixtures, and surface mounted fluorescent or LED fixtures specifically listed for closet use. See TABLE 5 for clearance requirements.

**TABLE 5: CLOSET LIGHT FIXTURE CLEARANCES TO STORAGE AREA<sup>1,2</sup>**

<b>FIXTURE TYPE</b>	<b>LOCATION</b>	<b>FLUORESCENT BULB, INCHES</b>	<b>INCANDESCENT AND LED BULB, INCHES</b>
Surface mounted	Wall/partition above door or ceiling	6	12
Recessed	Any wall/partition or ceiling	6	6

<sup>1</sup> Surface mounted fluorescent and LED bulbs are permitted in storage areas when identified and listed for this use.

<sup>2</sup> Exposed, or partially exposed, incandescent bulbs are prohibited.