



## Building Safety Division

# Technical Bulletin

**Subject:** Finished Basement Egress

**Date:** May 20, 2022

**No:** 22-01

**Summary:** Finished basements and bedrooms require an emergency escape and rescue opening (EERO). This technical bulletin clarifies the EERO requirements when a basement contains a bedroom and when additional windows in a basement are provided and the requirements for ladders and window well covers.

**Effective Date:** Immediately

**Background:** For the construction of new homes, the International Residential Code requires basements and bedrooms to have an emergency escape and rescue opening (e.g., window or door) to the outside with sufficient size and sill height to ensure safe egress for occupants and ingress for firefighters equipped with self-contained breathing tanks. Basement windows acting as an EERO require a window well with dimensions that will also facilitate egress/ingress and ladders or steps when the window well is greater than 44 inches deep. See Figures 1 and 2 below.

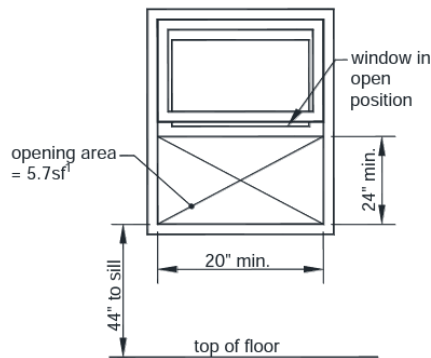

<sup>1</sup> Windows opening directly to outside in a walk-out condition are permitted to have an opening area equal to 5.0 square feet.

**FIGURE 1: EMERGENCY ESCAPE AND RESCUE OPENING REQUIREMENTS**

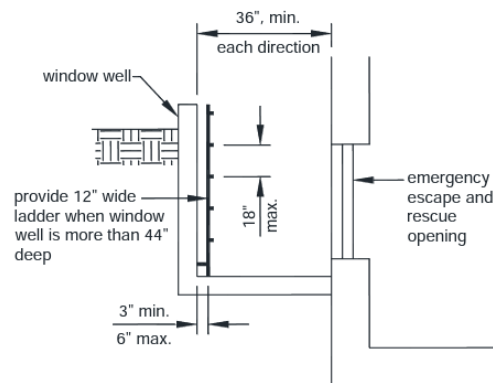

**FIGURE 2: WINDOW WELL REQUIREMENTS**

**Policy:** The policy herein is to clarify basement egress requirements when bedrooms or additional windows are installed and the minimum requirements for window well ladders and covers.

- **Basements with bedroom(s).** When a basement has one or more bedrooms, each must have an EERO. However, the EERO in the bedroom(s) can serve as the required basement EERO.
- **Basements with additional windows.** If a basement is served by a compliant EERO and associated window well, any additional basement windows, regardless of their dimensions or opening size, area not required to be served by an EERO-compliant window well.
- **Window well ladders.** All window wells associated with an EERO and deeper than 44 inches shall be equipped with code-compliant ladders or steps.
- **Window well covers.** Window wells deeper than 30 inches shall be covered. Covers shall be capable of resisting a 40 pound per square foot live load. Covers associated with an EERO and shall be releasable or removeable from the egress side without the use of a key, tool, special knowledge or a force greater than that required for the normal operation of the EERO.

If you have any questions regarding this policy, please contact Ryan Webster in the Building Safety Division at 303-227-8780.

**Approved by:** Brian Foley, P.E., Chief Building Official  
Community Development, Building Safety Division  
7887 East 60<sup>th</sup> Avenue  
Commerce City, CO 80022  
303-289-3694