



**Oil and Gas Permit Application**

**Blue Jay Well Site**

**Section 1 – Project Narrative and Schedule**

**Commerce City Development**

# **Blue Jay Well Site**

## **Oil and Gas Permit Application Narrative**

### **Introduction**

Extraction Oil & Gas, Inc. (Extraction) submits this application for an Oil and Gas Permit (OGP) concerning the Blue Jay oil and gas location, or “Well Site” in accordance with the Regional Operator agreement between Extraction and the City of Commerce City (the “City”). The application seeks to permit the drilling, completing, and installation of related surface production equipment for one (1) Well Site, (1) one access road and up to eighteen (18) horizontal wells on property located in Commerce City, Colorado for the Blue Jay Well Site. The drilling schedule is subject to change due to economic conditions, business development priorities, and contract availability. However, pad construction is tentatively scheduled to commence in mid-2022; drilling and completions operations are scheduled to occur during late 2022 and into early 2023.

The Blue Jay Well Site will have wells and production facilities permanently located on the Well Site. Well Site and “Well Pad” are used interchangeably in this application and generally refer to the “Well Site” as defined in the Regional Operator Agreement. The wells and associated production facilities under this application are being proposed on a single site in the Southeastern quarter of Section 3, Township 2 South, Range 66 West of the 6<sup>th</sup> P.M on parcel number 0172303400001. The horizontal drilling technique eliminates the need to develop additional Well Sites, thus reducing the overall footprint needed on the surface if otherwise developed with vertical and/or directional wells. This well pad and the subsequent 18 wells are currently planned to produce from Drilling and Spacing unit(s) covering one or more drilling unit(s) in the Niobrara and Codell formations of the Denver-Julesburg (DJ) Basin. As the subsurface permits are not yet approved, the spacing unit and specific wellbore details may change through the state permitting process but should not impact this local siting permit.

This permit application, pursuant to Section 21-5266 of the Commerce City Land Development Code, includes a full description of the site preparation, drilling, completion, production, and final abandonment processes.

### **Operating Plan**

The Operating Plan is divided into the site preparation, drilling phase, protection of fresh water, completion phase, production phase, and the abandonment and reclamation of wells and the Well Site. All operations will be consistent with Commerce City code and Colorado Oil and Gas Conservation Commission (“COGCC”) rules and regulations, specifically those set forth in the following series:

- 300 Series: Drilling, Development, Producing, and Abandonment
- 600 Series: Safety Regulations

- 800 Series: Aesthetic and Noise Control Regulations
- 1000 Series: Reclamation Regulations
- 1100 Series: Flowline Regulations

### **Site Preparation (21-34 days)**

The proposed pad will be approximately 14.0 acres in size during construction and drilling and completions operations. Site preparation will include removal of current grass vegetation and stockpiling of topsoil, earthwork operations to grade the pad level for drilling operations, platting the pad with road base material, and improvements to the access road where necessary. Additionally, stormwater controls and mitigation BMPs will be installed during construction of the pad.

### **Drilling Phase**

A drilling prognosis will be prepared prior to drilling which details the landing points, formation tops, total depths, mud design, and wellbore logging and casing programs for each well.

The drilling phase typically proceeds as follows:

- A conductor rig is moved onto the location to set conductor casing for each well; typically, conductor casing takes one day for every two wells to set. Conductor casing is set at depths of 75-200' and hold back the loose gravels and soil types from falling into the hole. The conductor casing is then cemented to the surface.
- After the conductor casing is set, a surface, or "spudder," rig is moved onto location to set surface casing. It typically takes one day per well to set surface casing.
- The smaller surface rig or larger regular rig drills to approximate depths of 1500' feet. For this Well Site, surface casing will be set at least 50 feet below the deepest known fresh water Fox Hills water well in the area or the base of the mapped Fox Hills aquifer formation; whichever is deeper. Surface casing is then run and cemented from this depth to the surface. Typical surface casing designs in the basin are a minimum of 1500' deep.
- Next, if not used for the surface casing, the regular drilling rig is moved onsite and rigged up. Mobilization of the drilling rig typically takes 2 to 4 days and a 24-hour drilling schedule is utilized. Under normal conditions, drilling is anticipated to take approximately 4 to 10 days per well.
- On Well Sites with multiple wells, the wellheads are typically planned at 20 to 28 feet separation. The rig is set up on the first well to be drilled, then skids or walks to each subsequent well.

- Once the total depth is reached for a well, the drill string is removed from the hole.
- Prior to running production casing, one well per pad has open-hole logs run to meet COGCC requirements if an offset well's logs are not available or are insufficient. Logs are run to determine sufficient cement coverage and the stratigraphy of the formation. The objective target formations for this project are mapped and estimated to be between 7000-7600' deep.
- Production casing is then run, set in the hole, and cemented in place to provide integrity and isolate the deeper hydrocarbon bearing formations.
- Next, the blow out preventer is removed, the well is properly capped and secured and then the rig skids to the next well on the pad.
- Once all wells on site are drilled, cased, cemented and the well heads capped and secured, the drilling rig is demobilized and moved offsite.

### **Protection of Fresh Water**

The COGCC sets forth specific requirements for casing setting depths necessary to protect ground water sources, and all drilling permits ensure that those setting depths have been approved. The Fox Hills sands of the late Cretaceous age are important fresh water aquifers in the western portion of the DJ Basin. In addition, there are numerous discontinuous sands of secondary importance that lie directly below the Fox Hills formation. These ground water sands are found from the surface to a depth of approximately five hundred (500) feet in the north and eastern portions of the basin and from the surface to a depth of approximately one thousand (1,000) feet or more in the south and western parts of the basin.

In order to ensure the protection of all fresh water resources, 9-5/8" steel surface casing is set to a depth at least fifty (50) feet below the base of the deepest known Fox Hills sands or water well, whichever is deeper, as required by the COGCC and is cemented from the bottom of the pipe up to the surface. The COGCC reviews all drilling permit applications for adequate surface casing setting depths and cementing programs based on subsurface ground water maps prepared by the State Water Engineer, offset well data and all available water well data.

### **Completion Phase**

Completion operations commence once the production casing cement has had sufficient time to cure. Typically, cement will cure to maximum strength within 72 hours. The quality is verified by a cement bond log ("CBL"). Occasionally there is a longer time delay between drilling and completions due to equipment availability and scheduling.

Typically, the completion phase proceeds as follows:

- The well is perforated based on an open-hole log analysis. Perforation occurs at specified intervals and pierces the steel casing, the cement and the formation.
- The well is then fractured hydraulically creating hairline cracks in the formation to produce tiny avenues that allow the hydrocarbons to flow from the formation. Sand is used as a propping agent to preserve the hairline cracks opened in the formation. Typically, six to nine fracturing operations or stages can be completed per day per well, at a rate of up to four wells simultaneously, including time to rig up, pump, and rig down. This process requires multiple, high-pressure, truck-mounted pumps and the associated portable equipment. Once the process is complete, all associated equipment is moved offsite.
- The well is then flowed back for 1-20 days to portable tanks. The length of this process is dependent on the number of wells on a pad and the length of the laterals. These flow back fluids are trucked offsite. Where possible, the wells will be flowed back through the facility and into the pipelines
- If necessary, tubing is run inside the casing to increase production efficiency. This process typically takes 1 to 3 days.

### **Production Phase**

The production phase begins once temporary flowback equipment has been removed and production is being routed through the permanent production facility. New production facilities are constructed in accordance with COGCC rules and regulations as illustrated in the site plan.

The Blue Jay Well Site production facility in general consists of the following surface equipment:

- 18 Separators: Separates production fluid into their constituent components of oil, gas and water.
- 2 Meter House / Skids : Measures the amount of produced gas.
- 2 Surge Vessels: helps to steady the flow of production
- 1 Maintenance Vessel: pressurized vessel that can be used to unload wells during maintenance operations
- 4 Compressors: for gas lift, gas sales, and low- pressure compression
- 2 Instrument Air Skid: for operating equipment and valves on-site
- 2 Enclosed Combustor Devices (ECDs): To be used only on an as-needed basis to incinerate natural gas that cannot be captured, processed and sold for commercial resale and/or in the event of an unplanned shut-down of the pad.
- 2 Lease Automated Custody Transfer Unit (LACT Unit): Safely measures oil loaded out by reducing the utilization of hatches and reducing any uncontrolled releases of emissions.
- 2 Modular Large Volume Tanks (MLVTs): temporary fresh water tanks for well completion operations will be used in lieu of historic in-ground pits or multiple mobile 500 bbl steel tanks. The use of MLVTs significantly reduces the number of truck trips and decrease time required for set-up of completion operations.

- 4 Pump Skids: If needed, these pumps can assist in overcoming hydraulic backpressure in gathering lines and in piping.
- 2 produced water tanks: for temporary storage of produced water. Typically 12' in height with 400 bbl of storage capacity.
- 1 Heater Treater: allows for additional separation of oil and gas products on-site

Per COGCC regulations, secondary containment will be constructed around the facility. The secondary containment steel berms will be 26 to 36 inches tall and will fully encircle the facility separators. Given the size of the containment area and steel berm height, the secondary containment is sized to exceed the requirement of 1.5 times the maximum volume of liquids that such equipment will contain at any given time plus sufficient freeboard to prevent overflow. Containment facilities will be painted in accordance with COGCC Rule 804. Additionally, the Blue Jay facility will have an additional tertiary berm around the production facility. After the Blue Jay facility is constructed, a Spill Containment and Counter measures (SPCC) plan that complies with all EPA requirements will be prepared and submitted to Commerce City and the South Adams County Fire District.

The wellheads will be connected to the separators via flowlines that will be buried 3 to 4 feet deep. The flowlines are typically 2-inch-diameter schedule 160 welded steel, coated.

Once the production phase of the wells commences, daily monitoring of the wells begins. Daily reports consist of equipment measurements, production estimates, pressure readings, and general facility care and maintenance. Production data is compiled and recorded in a monthly report to the COGCC. The production phase continues until a well is no longer productive, or it is no longer financially viable to continue production. It is estimated that the average life of each well at this location will be 20 to 30 years.

## **Reclamation**

After drilling, completion, and flowback operations are complete, the Blue Jay pad will enter the interim reclamation period which includes re-contouring and reseeding around the edges of the pad to allow for daily operations of the oil and gas facility, access to the wells, maintenance of the facility and wells, work-overs, and normal production activity. All temporary tanks and equipment will be removed from the location. The Well Site size will be reduced to approximately 6.1 acres and will be fenced and landscaped per this application and COGCC requirements within 6 months of the conclusion of drilling and completion operations.

Refer to Section 15 "Interim Reclamation Plan" and Section 21 "Landscaping Plan" for additional information. Below is a table showing species type and number of trees, bushes and seeding proposed for the landscaping of the Blue Jay Well Site.

TREES		
COMMON NAME	BOTANICAL NAME	QTY
Common Hackberry	Celtis Occidentalis	7
Kentucky Coffee Tree	Gymnocladus Bioica	7
Adams Crabapple	Malus X 'Adams'	8
Rocky Mountain Juniper	Juniperous Scopulorium	12
Ponderosa Pine	Pinus Ponderosa	14
Pinyon Pine	Pinus Cembroides Edulis	9
SHRUBS		
Apache Plume	Fallugia Paradoxa	31
Armstrong Juniper	Juniperous Chinesis 'Armstrong'	16
Mugo Pine	Pinus Mugo	15
Western Smooth Sumac	Rhus Lanceolata	30
GROUND COVERS		
(30%) Western Wheatgrass	Pascopyrum Smithii	
(30%) Indian Ricegrass	Achantherum Hymenoides	
(20%) Slender Wheatgrass	Elymus Trachycaius	
(20%) Sand Dropseed	Sporobolus Cryptanrus	
Total Seeding		346,638 sq/ft

### **Plugging and Abandonment of Wells & Facilities**

Once production has concluded from the site, the site will be fully reclaimed in conformance with Commerce City regulations as well as the COGCC regulations. All surface restoration shall be accomplished and completed to the reasonable satisfaction of the surface owner or as soon as practical (weather permitting), and in accordance with regulatory agencies' standards. The wells will be permanently plugged, capped and abandoned and all roads and all production equipment will be removed. The plugging of the wells will include installation of a series of required cement plugs in the wellbore to eliminate future flow from the well, in accordance with Section 1000 of COGCC rules and regulations. Surface restoration will include removal of any above-ground casing and installation of regulation markers that will not interfere with future surface use. After the well has been plugged, flowlines will be flushed of all hydrocarbons and removed in accordance with Rule 1103 of COGCC rules and regulations and the Operator Agreement. All reseeded shall be done with grasses consistent with the native mix or other grasses reasonably requested by the surface owner.

### **Water Source**

Extraction acquires water rights from various sources in surrounding counties, which can be used during drilling and completion operations. Extraction typically contracts with third parties to transport and store the water in temporary modular large volume tanks (MLVTs) in a central location for use during completion at the pad. Transportation of water to the MLVTs and the pad for completions will be completed using temporary "lay flat" water lines on the surface and removed after use. This technology eliminates the need to truck water to the pad during

completion operations. If available, South Adams County Water and Sanitation District (SACWSD) water may be used for irrigation of permanent landscaping or other phases of the project.

### **Weed Control**

All areas, including well heads and production facilities, will be kept free of weeds, rubbish, and other waste material. As much as possible, all areas will be kept free of noxious weeds. If noxious weeds are identified on-site, the area will be treated as soon as possible in an effort to prevent the weed from flowering and spreading. To the greatest extent possible, machinery and equipment will not be parked or staged in weed infested areas.

### **Drainage & Erosion Control**

Proper stormwater controls will be installed around the tank battery and drilling pad during construction. The wellhead access road will be crowned, ditched and graveled, and culverts for cross drainage will be installed. Storm-water controls will also be installed around the spoil piles to prevent sediment migration. No changes in the current drainage patterns are anticipated. Stormwater control, as detailed in the subsections of this permit, have been designed to comply with Commerce City Code requirements. A Stormwater/Erosion Control BMP will also be filed with the COGCC as part of the Oil and Gas Location Assessment (COGCC Form 2A).

### **Sanitary Facilities**

Extraction personnel and contractors will utilize portable sanitary toilets and wash stations. Since there are no personnel on the location continuously during the long-term production phase, no city services or permanent sanitary services of any kind are required (other than the possible use of municipal water for landscaping). All personnel and contractors who visit the site are responsible for picking up and disposing of any debris.

### **Public Utilities**

Extraction is planning to utilize high line power for electricity at the well site, and may also utilize SACWSD water, if available, for permanent landscaping or other project uses.

### **Mitigation Measures and Best Management Practices**

#### **Wildlife & Environmental**

The Blue Jay pad and its respective production facility are not located within USFWS (United States Fish and Wildlife Service) and CPW (Colorado Parks and Wildlife) mapped layers for sensitive species. The pad, wells and facilities are outside of the FEMA mapped flood plain area. A full biological Initial Site Assessment was completed on April 10, 2019. These items are described in Section 19 and 24 of the permit application, respectively.



Extraction will also collect baseline water quality sampling per COGCC 381A.f. and 609, as well as is specified in the Operator Agreement. This testing will evaluate baseline water quality and confirm post-drilling water quality near the wellsite. Details of this program are contained in the Water Monitoring Plan, Section 12.

### **Noise Control**

Any operations involving the use of a drilling rig, workover rig, or fracturing and any equipment used in the drilling, completion or production of a well are subject to and will comply with the noise regulations set forth by COGCC Rule 802 and BMP 6 of the Operator Agreement, which specifies 4 dB(A) higher than baseline ambient sound measured at 1,000 ft. from the sound walls at the Well Site. Additionally, sound walls (approximately 32' in height) will be installed on a portion of the perimeter of the wellsite to mitigate both A-scale and C-scale noise. The Blue Jay site is within the DIA noise contour and also in close the proximity to E-470, both of which increase the background noise levels in the area. Further discussion of noise mitigation is covered in Section 3 of this permit application.

### **Visual Impacts/Screening**

During drilling and completion operations, the combination of natural topography/existing berming, combined with the use of sound walls, will provide significant visual screening. The production facilities will be painted in accordance with the COGCC Rule 804 regarding Visual Mitigation. Permanent visual screening / landscaping is being proposed to match the surrounding scenery and provide visual barriers to the wellsite. The Visual Mitigation Plan is in Section 20 of the permit application and complies with BMP 5 of the Operator Agreement.

### **Odor**

All applicable COGCC regulations related to odor as well as BMP 1(I) of the Operator Agreement will be adhered to by the Operator. No noxious, prolonged or unusually high amounts of odor are expected from the proposed drilling of the wells. Operations will be conducted in such a manner as to not create a nuisance or hazard to the public. To this end, the operations may utilize drilling mud coolers, wiping down the drill pipe as it is removed from the hole, and increasing additive concentrations as necessary. Additionally, no fragrances will be used to mask odor.

### **Air Pollution**

As described in Section 8 of the permit application, Air Quality Plan, all drilling, well completion and production activities will comply with the permit and control provision of the Colorado Air Quality Control Program, Title 25, Article 7, C.R.S. Several BMPs are being implemented to reduce and eliminate odors, including the use of pitless drilling systems, green completions, electrification of permanent equipment, and use of pipelines. Additionally, Extraction will

provide funds to the City to conduct additional air monitoring, as provided in the Operator Agreement.

### **Signage**

Extraction will maintain all signage pursuant to Commerce City and COGCC Rules and Regulations.

### **Access Roads & Maintenance**

Extraction will maintain all access roads in compliance with Commerce City and Adams County Code. The proposed access road for the Blue Jay site crosses East onto another parcel in unincorporated Adams County to avoid having to cross the 3<sup>rd</sup> Creek flood plain just South of the wellsite. Extraction has approval from the adjacent landowner in Adams County to build the access road and use it for permanent access to the Blue Jay site. Extraction will obtain an Access Permit from Commerce City or Adams County as appropriate to tie the well pad road to the corresponding city road. Please see the attached Site Plan. The access road will be bladed to minimize wet weather damage. Fugitive dust will be kept to a minimum. All lease roads leading to the well site will be designated and maintained to support fire vehicles, equipment and apparatus. Extraction will work with the Commerce City road department to ensure any damage caused by Extraction activity is property repaired. A traffic impact study and trip generation analysis has been performed by a professional engineer, as described in Sections 6 and 7 of the permit application.

### **Waste Disposal**

Extraction will dispose of all wastes in accordance with COGCC and/or the Colorado Department of Public Health and Environment rules and regulations. Extraction will provide the County copies of all waste management reports upon request. Per the Operator Agreement, Extraction will not drill any wastewater disposal wells inside Commerce City as a part of this project. Sections 10 and 11 of this permit application provide more information on waste disposal practices that will be implemented by Extraction.

### **Light Mitigation**

Temporary lighting will be on site for the drilling, completions and flowback phases of the project. The well facility will have permanent lights for safety and general maintenance, emergencies and other pertinent operations that require light for execution. All permanent lighting of the Well Site shall be directed downward or shielded. Temporary lighting shall conform to the COGCC's Rules and Regulations. Lighting details are included in Section 6 of the permit application.

## **Fencing**

All equipment will be fenced as required by defined the COGCC 600 Series Rules. Fence details are included in the site plan.

## **Airport Height Overlay**

The well site lies approximately 16,300 feet (3.1 miles) Northwest of existing Runway 7/25 at Denver International Airport.

Extraction Oil & Gas has no plans to utilize permanent or temporary equipment that will meet or exceed the 200 ft. height requirement. In the event this changes Extraction will obtain necessary permit from FAA prior to constructing and utilizing such equipment.

## **Schedule of Operations**

There are a multitude of state and local permits that will be required before construction of this location can be initiated. The submission and approval timelines for many of these permits is increasingly difficult to predict. At this time, construction of the location is expected to begin in mid-2022. Drilling operations are expected to commence in 3Q 2022 and finish in late 2022. Completion operations will also begin in late 2022 and continue until mid-year 2023, at which point the wells will be turned to production. This is only an estimate of the schedule, and actual operations may differ from this forecast.

## **Contact Information**

### **Extraction's Emergency Response Line (24-hr)**

720-370-5540

### **Extraction Representative Designated to Receive Legal Notice:**

Eric Christ

370 17th Street, Suite 5300

Denver, CO 80202

Office: 720-974-7755

[echrist@extractionog.com](mailto:echrist@extractionog.com)

### **Project Manager for Extraction**

Spencer Crouch

370 17th Street, Suite 5300

Denver, CO 80202

Office: 720.354.4610

[scrouch@extractionog.com](mailto:scrouch@extractionog.com)

**Surface Owner Contact Info:**

TOWER EASTSIDE LLC

4100 E MISSISSIPPI AVE STE 500

GLENDALE CO 80246-3053



**Oil and Gas Permit Application**

**Blue Jay Multi-Well Pad**

**Appendix A – OGP Site Plan**

**Commerce City Development**

**Table of Contents**

**1.0 INTRODUCTION.....2**

## **1.0 INTRODUCTION**

The OGP Site Plan for Blue Jay Pad is shown on the following pages.



# OIL AND GAS OPERATIONS PLAN - OIL AND GAS PERMIT APPLICATION

## BLUE JAY MULTI-WELL PAD

### NORTHEAST QUARTER OF THE SOUTHEAST QUARTER

### SECTION 3, TOWNSHIP 2 SOUTH, RANGE 66 WEST

### COMMERCE CITY, ADAMS COUNTY, STATE OF COLORADO

**CONTACTS:**

**APPLICANT**  
EXTRACTION OIL & GAS INC  
370 17TH STREET, SUITE 5300  
DENVER, CO 80202

**PROPERTY OWNER**  
TOWER EASTSIDE LLC  
4100 E MISSISSIPPI AVE, STE 500  
GLENDALE, CO 80246-3053

**COMMERCE CITY ECONOMIC DEVELOPMENT**  
7857 E. 60TH AVE  
COMMERCE CITY, CO 80022  
303.289.3620

**ADAMS COUNTY SHERIFF'S DEPARTMENT**  
MICHAEL MCINTASH, ADAMS COUNTY SHERIFF  
303.654.1850

**SOUTH ADAMS COUNTY FIRE PROTECTION DISTRICT**  
6050 SYRACUSE STREET  
COMMERCE CITY, CO 80022  
303.288.0835

**LAND SURVEYOR**  
LAMP RYNEARSON  
4715 INNOVATION DR.  
FORT COLLINS, CO, 80525  
KELVIN WIESE  
970.226.0342

**PROJECT SURVEY CONTROL:**

**COORDINATE SYSTEM**

NAD83; COLORADO STATE PLANE, NORTH

\*PROJECT IS IN MODIFIED STATE PLANE COORDINATES. TO ACHIEVE GRID COORDINATES AND GRID DISTANCES SCALE ENTIRE PROJECT BY 0.999725024 FROM NGS BM A-457.

**HORIZONTAL CONTROL POINT**

NGS BM "A-457" N: 1215024.88 LAT: 39°55'17.87245"N  
E: 3189976.72 LONG: 104°49'21.56038"W

**VERTICAL DATUM**

NAVD 88 (GEOID 12B)

**BENCHMARKS USED**

NGS BM "BARR LAKE" PID A93299 ELEVATION = 5150.28  
NGS BM "A-457" PID DH9139 ELEVATION = 5066.14

**BASIS OF BEARING STATEMENT**

THE EAST LINE OF THE SOUTHEAST QUARTER OF SECTION 3-T2S-R66W BEARS SOUTH 00°11'17" WEST 2629.59 FEET BETWEEN THE EAST QUARTER CORNER OF SECTION 3, MONUMENTED BY A 2 1/2" ALUMINUM PIPE WITH 3 1/4" ALUMINUM CAP PLS 13155, AND THE SOUTHEAST CORNER OF SECTION 3, MONUMENTED BY A 2" ALUMINUM CAP PLS 24960, BASED ON THE COLORADO NORTH 0501 STATE PLANE COORDINATE SYSTEM, WITH ALL BEARINGS HEREIN RELATIVE THERETO.

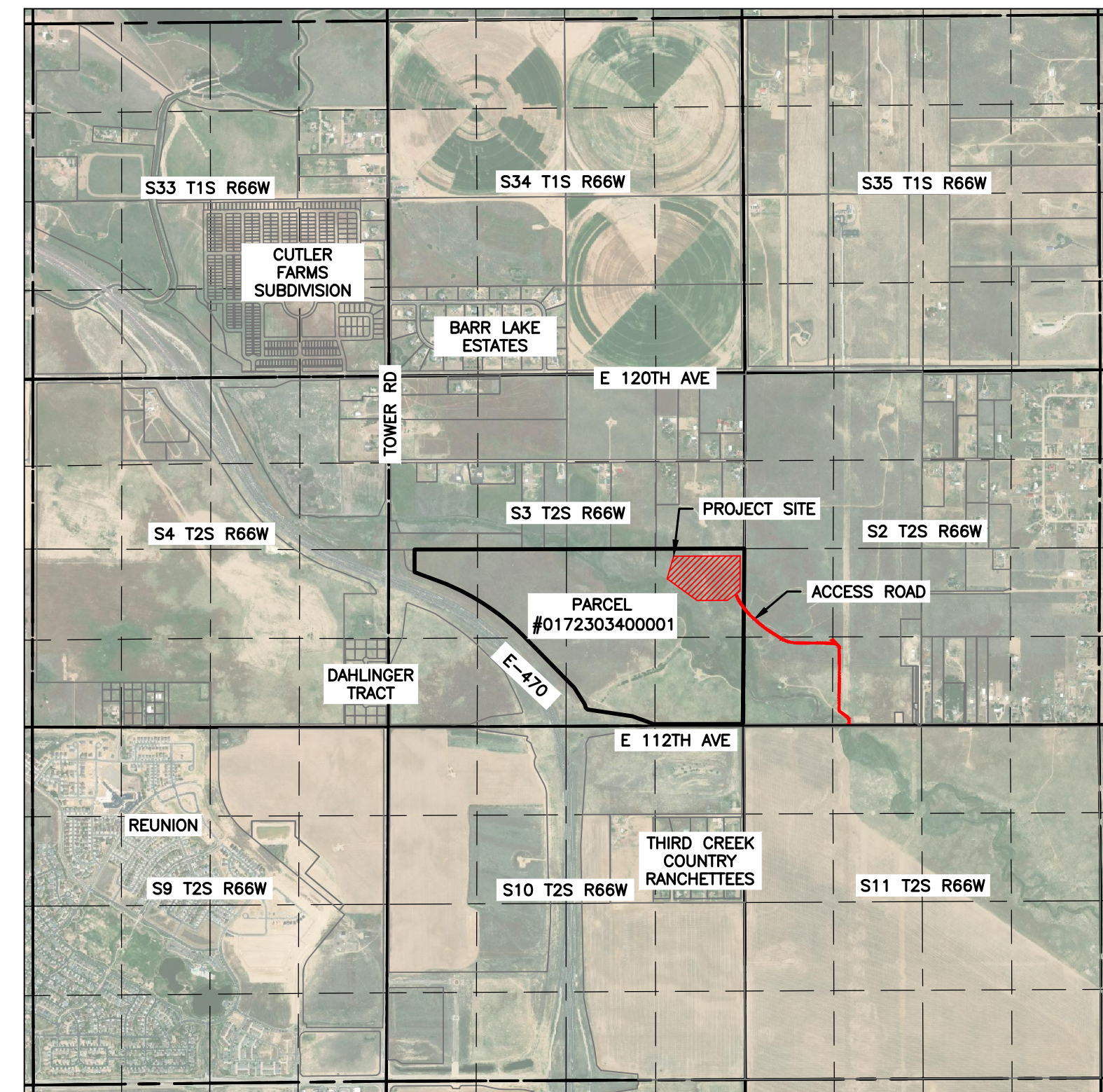

VICINITY MAP  
1"=2000'



DATA BLOCK	
WELL PAD ACREAGE	14.10 AC (DISTURBANCE AREA) 11.38 AC (DRILL/PROD) 6.14 AC (INTERIM RECLAIMED)
NUMBER OF WELLS	18
MAX. HEIGHT OF STRUCTURES	42'-0"
ZONING CLASS	PUD-PRIME SITE

SHEET LIST TABLE	
SHEET NUMBER	SHEET TITLE
1	COVER
2	IMPACT AREA MAP
3	DRILLING AND PRODUCTION SITE PLAN
4	INTERIM RECLAIMED SITE PLAN
5	DETAILS
6	LANDSCAPING PLAN
7	LANDSCAPING NOTES

WELLS			
①	BLUE JAY 3W-30-01	⑩	BLUE JAY 3W-30-10
②	BLUE JAY 3W-30-02	⑪	BLUE JAY 3W-30-11
③	BLUE JAY 3W-30-03	⑫	BLUE JAY 3W-30-12
④	BLUE JAY 3W-30-04	⑬	BLUE JAY 3W-30-13
⑤	BLUE JAY 3W-30-05	⑭	BLUE JAY 3W-30-14
⑥	BLUE JAY 3W-30-06	⑮	BLUE JAY 3W-30-15
⑦	BLUE JAY 3W-30-07	⑯	BLUE JAY 3W-30-16
⑧	BLUE JAY 3W-30-08	⑰	BLUE JAY 3W-30-17
⑨	BLUE JAY 3W-30-09	⑱	BLUE JAY 3W-30-18

**ABBREVIATIONS:**

MLVT = MOBILE LARGE VOLUME TANK  
ELEV = ELEVATION  
OGGA = OIL AND GAS OPERATIONS AREA  
COGCC = COLORADO OIL AND GAS CONSERVATION COMMISSION  
AC = ACRE



**LAMP RYNEARSON**

4715 INNOVATION DR., STE. 100  
FORT COLLINS, CO 80525  
970.226.0342  
LampRynearson.com



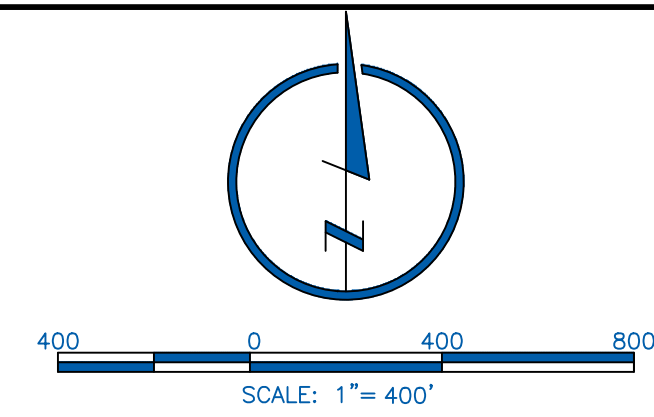
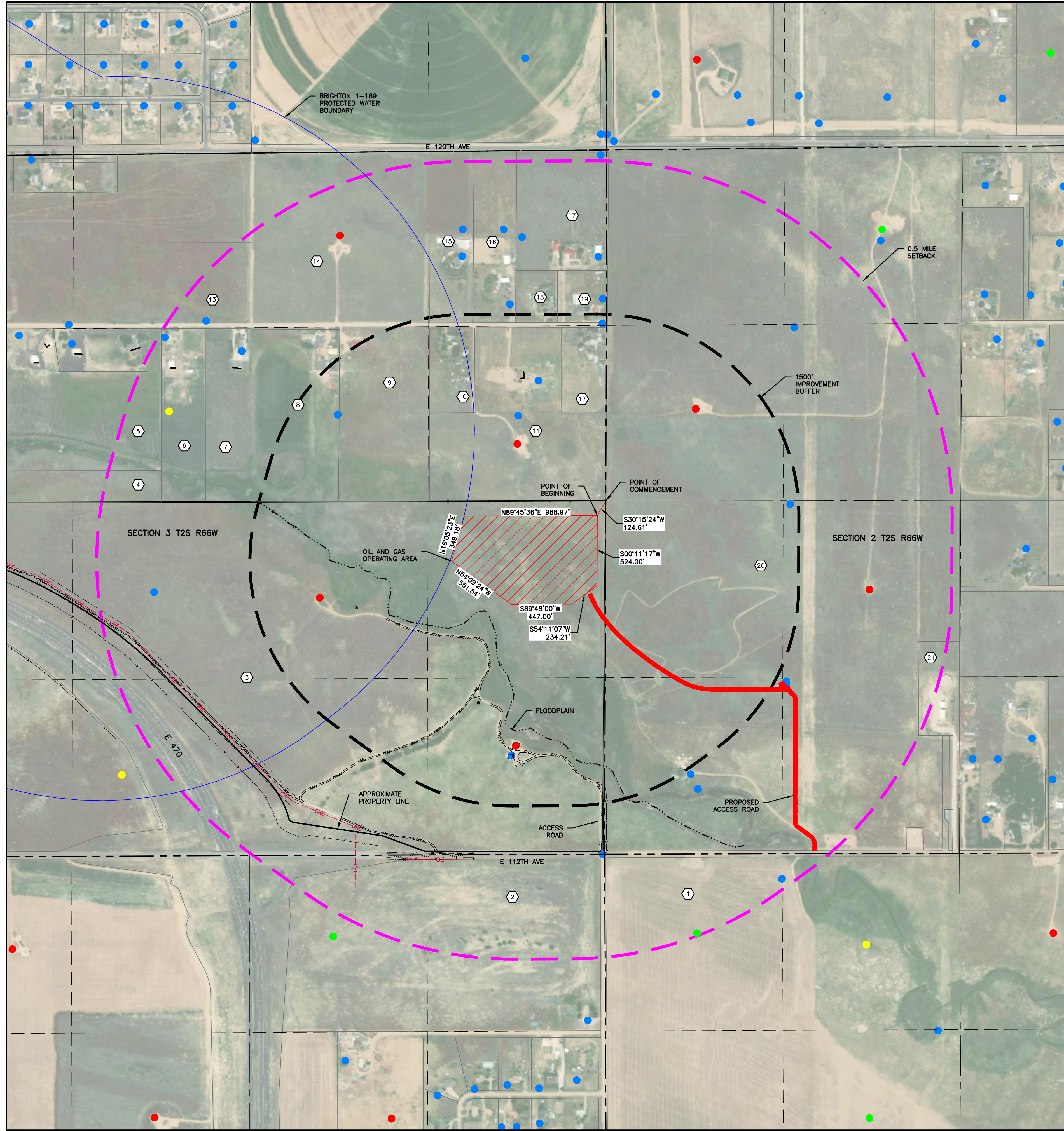

- LEGEND**
- 1500' SETBACK OGOA
  - EXISTING GAS LINE
  - OH— EXISTING OVERHEAD ELECTRIC
  - EXISTING FENCE
  - EXISTING ROAD
  - BRIGHTON 1-189 PROTECTED WATER BOUNDARY
  - EXISTING ELECTRIC LINE
  - APPROXIMATE PROPERTY LINE
  - 0.5 MILE SETBACK FROM OGOA
  - SECTION LINE
  - 1/16 LINE
  - OGCC OIL AND GAS WELL
  - ABANDONED OIL AND GAS WELL
  - SHUT-IN OIL AND GAS WELL
  - EXISTING WATER WELL

PARCELS WITHIN 0.5 MILE IMPROVEMENT BUFFER			
PARCEL NUMBER	OWNER'S NAME	MAILING ADDRESS	
1	SMT INVESTORS LIMITED PARTNERSHIP ET AL	1242 E JACKSON ST, PHOENIX, AZ 85034-2342	
2	RYEL FAMILY PARTNERSHIP LLLP	19983 E 108TH PL, COMMERCE CITY, CO 80022-9713	
3	TOWER EAST SIDE LLC	4100 E MISSISSIPPI AVE STE 500, GLENDALE, CO 80246-3053	
4	E-470 PUBLIC HIGHWAY AUTHORITY	22470 E 6TH PKWY NO. 100, AURORA, CO 80018	
5	MOLINA SILVIA E AND MOLINA JUAQUIN S	18900 E 188TH AVE COMMERCE CITY CO 80022-0510	
6	HITCH JEVAR D	19150 E 118TH AVE COMMERCE CITY CO 80022	
7	KAMPBELL DONNA J	19290 E 118TH AVE COMMERCE CITY CO 800229718	
8	MORGAN KERRY D AND MORGAN ROBERT D	20001 E 188TH AVE COMMERCE CITY CO 80022-9703	
9	MORGAN KERRY D	20001 E 188TH AVE COMMERCE CITY CO 80022-9703	
10	STEVENSON DAVID W	19750 E 118TH AVE COMMERCE CITY CO 80022-9723	
11	MORGAN KERRY D AND MORGAN ROBERT D	20001 E 188TH AVE COMMERCE CITY CO 80022-9703	
12	FIFER LARRY K AND FIFER DELORAS E	20090 E 118TH AVE COMMERCE CITY CO 80022	
13	KHAN ZULFIQAR	634 54TH AVENUE CT GREELEY CO 80634-4444	
14	FAMILY TRUST C/O PHILIP LUNNON	6306 UMBER CIR ARVADA CO 80403-7407	
15	HOGER BRUCE A	19751 E 118TH AVE COMMERCE CITY CO 80022	
16	BUZZITTA JOSEPH AND BUZZITTA KAREN	19851 E 118TH AVE COMMERCE CITY CO 80022-9703	
17	MORGAN KERRY D	20001 E 118TH AVE COMMERCE CITY CO 80022-9703	
18	TURNER BRANDI A TRUST	19901 E 118TH AVE COMMERCE CITY CO 80022-9779	
19	DELGADO ROBERTO A AND DELGADO CRYSTAL J	20085 E 118TH AVE COMMERCE CITY CO 80022-9703	
20	ACKARD NORTH LTD	11503 ROYAL SILVER DR HOUSTON TX 77082	
21	EAST CHERRY CREEK VALLEY WATER AND SANITATION DISTRICT	6201 S GUN CLUB ROAD AURORA CO 80016	

**LEASE PARCEL DESCRIPTION:**  
 A LEASE PARCEL LOCATED IN THE NORTHEAST QUARTER OF THE SOUTHEAST QUARTER OF SECTION 3, TOWNSHIP 2 SOUTH, RANGE 66 WEST OF THE 6TH P.M., COMMERCE CITY, ADAMS COUNTY, COLORADO, SAID LEASE PARCEL BEING MORE PARTICULARLY DESCRIBED AS FOLLOWS:  
 COMMENCING AT THE EAST QUARTER CORNER OF SAID SECTION 3; THENCE SOUTH 30°15'24" WEST FOR 124.61 FEET TO THE POINT OF BEGINNING;  
 THENCE SOUTH 00°11'17" WEST FOR 524.00 FEET; THENCE SOUTH 54°11'07" WEST FOR 234.21 FEET; THENCE SOUTH 89°48'00" WEST FOR 447.00 FEET; THENCE NORTH 54°09'24" WEST FOR 551.54 FEET; THENCE NORTH 16°05'23" EAST FOR 349.18 FEET; THENCE NORTH 89°45'36" EAST FOR 988.97 FEET TO THE POINT OF BEGINNING.  
 SAID LEASE PARCEL CONTAINS APPROXIMATELY 14.10 ACRES, MORE OR LESS.  
**BASIS OF BEARINGS**  
 THIS DESCRIPTION IS BASED ON COLORADO STATE PLANE COORDINATES IN WHICH THE EAST LINE OF THE SOUTHEAST QUARTER OF SECTION 3, TOWNSHIP 2 SOUTH, RANGE 66 WEST OF THE 6TH P.M., BEARS SOUTH 00°11'17" WEST FOR 2629.59 FEET BETWEEN THE EAST 1/4 CORNER OF SAID SECTION 3, MONUMENTED WITH A FOUND 3 1/4" ALUMINUM CAP, L.S. 13155, 1991, AND THE SOUTHEAST CORNER OF SAID SECTION 3, MONUMENTED WITH A FOUND 2" ALUMINUM CAP, L.S. 24960, 1994, IN A MONUMENT BOX.  
**VERTICAL DATUM**  
 NAVD 88 (GEOID 12B)  
**BENCHMARKS USED**  
 NGS BM "BARR LAKE" PID A83299 ELEVATION = 5150.28  
 NGS BM "A-457" PID DH9139 ELEVATION = 5066.14  
**COORDINATE SYSTEM**  
 NAD83; COLORADO STATE PLANE, NORTH  
 \*PROJECT IS IN MODIFIED STATE PLANE COORDINATES. TO ACHIEVE GRID COORDINATES AND GRID DISTANCES SCALE ENTIRE PROJECT BY 0.999725024 FROM NGS BM A-457.  
**HORIZONTAL CONTROL POINT**  
 NGS BM "A-457" N: 1215024.88 LAT: 39°55'17.87245"N  
 E: 3189976.72 LONG: 104°49'21.56038"W  
**BASIS OF BEARING STATEMENT**  
 THE EAST LINE OF THE SOUTHEAST QUARTER OF SECTION 3-T2S-R66W BEARS SOUTH 00°11'17" WEST 2629.59 FEET BETWEEN THE EAST QUARTER CORNER OF SECTION 3, MONUMENTED BY A 2 1/2" ALUMINUM PIPE WITH 3 1/4" ALUMINUM CAP PLS 13155, AND THE SOUTHEAST CORNER OF SECTION 3, MONUMENTED BY A 2" ALUMINUM CAP PLS 24960, BASED ON THE COLORADO NORTH 0501 STATE PLANE COORDINATE SYSTEM, WITH ALL BEARINGS HEREIN RELATIVE THERETO.

**LAMP RYNEARSON**  
 4715 INNOVATION DR., STE. 100  
 FORT COLLINS, CO 80525  
 970.226.0342  
 LampRyNearson.com



FOR REVIEW  
 NOT RELEASED FOR CONSTRUCTION  
 PETER J CARLSON

BLUE JAY MULTI-WELL PAD  
 IMPACT AREA MAP

BLUE JAY MULTI-WELL PAD  
 NE/4, SE/4, SEC 3 T2S R66W

**811** ALL UTILITIES ARE SHOWN BASED ON THE INFORMATION AVAILABLE TO THE ENGINEER. THERE IS NO GUARANTEE ALL UTILITIES ARE SHOWN OR THAT THE LOCATION, DEPTH, AND SIZE OF EACH FACILITY IS CORRECT. THE CONTRACTOR IS RESPONSIBLE FOR LOCATING ALL UTILITIES AND SERVICE LINES PRIOR TO CONSTRUCTION.  
 Know what's below.  
 Call before you dig.

REVISIONS

NO.	DATE	DESCRIPTION

DESIGNER / DRAFTER  
 JASON P. MCNEILL  
 DATE  
 10/03/2019  
 PROJECT NUMBER  
 0218002.07  
 BOOK AND PAGE

L:\Engineering\0218002.07 - Blue Jay\DRAWINGS\CONSTRUCTION\DRAWINGS\0218002.07-IMPACT AREA MAP.dwg, 10/2/2019 1:58:25 PM, DILLON STARK, LAMP RYNEARSON



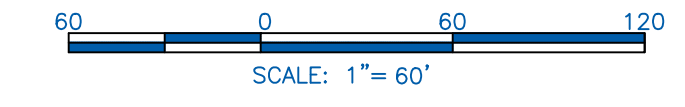
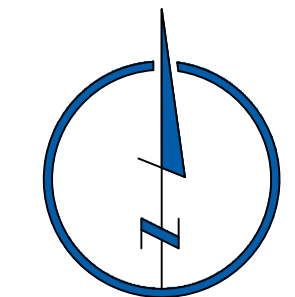
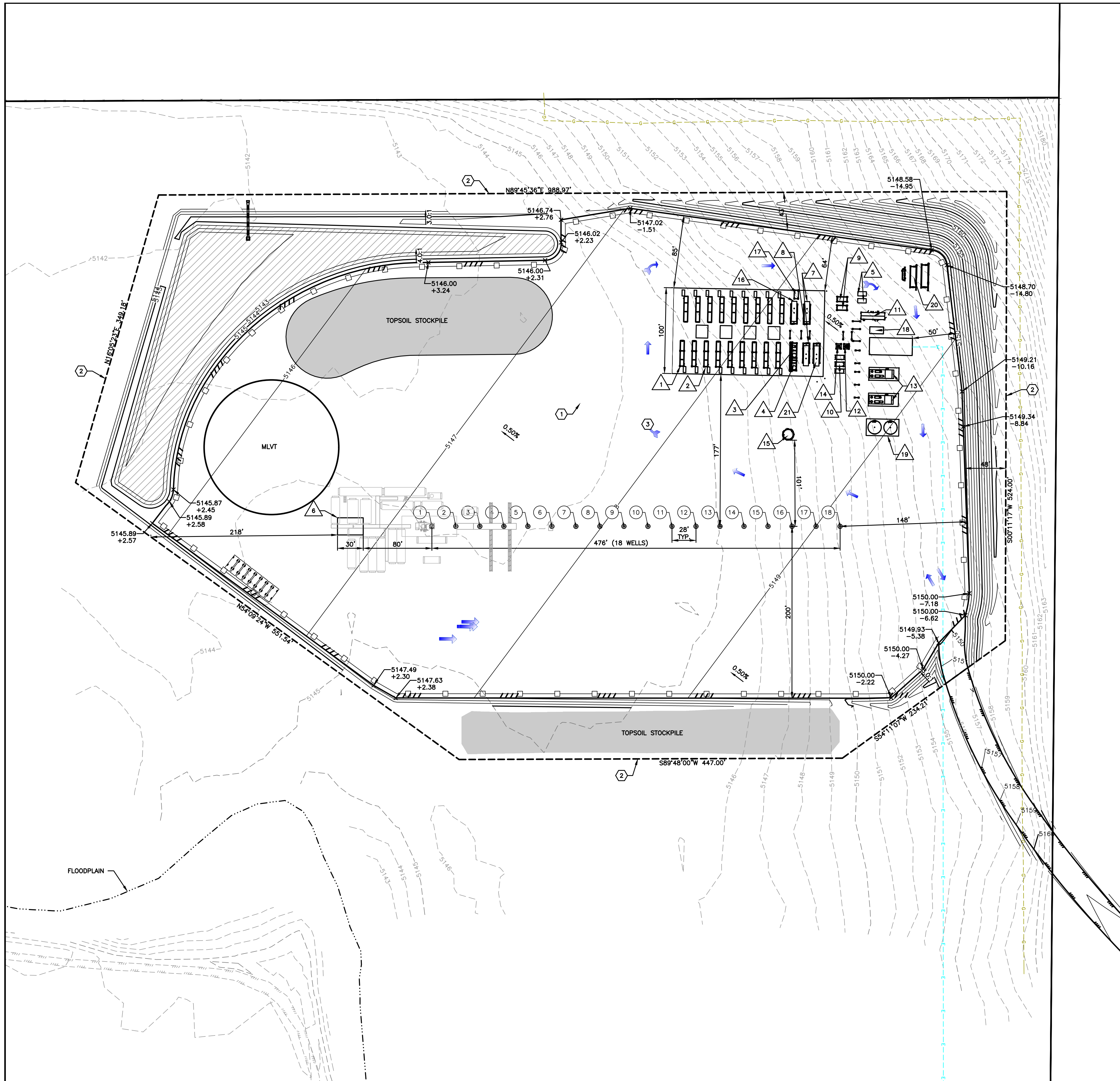

EQUIPMENT		
#	COUNT	NAME
1	28	SEPARATOR
2	16	INLET SKID
3	1	HP 2 PHASE
4	1	HP 2 PHASE EXTENSION
5	2	GAS METER BUILDING
6	2	GAS LIFT SHED
7	2	SURGE VESSEL (2PH)
8	2	SURGE VESSEL TEST LINE CONN. ADDITIONS
9	2	OIL PUMP SKID

10	3	WATER PUMP SKID
11	1	OIL & WATER METER BUILDING
12	1	LP SCRUBBER SKID
13	2	LP GAS COMPRESSOR SKID
14	1	FUEL GAS SCRUBBER
15	1	COMBUSTOR - Q UNITS
16	1	MAINTENANCE VESSEL (3PH)
17	1	MAINTENANCE PUMP SKID
18	1	INSTRUMENT AIR
19	2	PRODUCED WATER TANKS
20	1	LAUNCHERS
21	1	HEATER TREATER VESSEL

**LEGEND**

- EXISTING GAS LINE
- EXISTING FENCE LINE
- EXISTING OVERHEAD POWER LINE
- PROPOSED UNDERGROUND ELECTRIC LINE
- EDGE OF GRAVEL
- LIMITS OF OGGA
- EXISTING ROAD
- EXISTING CONTOUR LINE
- PROPOSED CONTOUR LINE
- DRAINAGE SWALE CENTER LINE
- SOUND WALL
- TRAFFIC FLOW
- TOP SOIL STOCKPILE
- SEDIMENT BASIN
- SPOT ELEVATION
- DEPTH OF CUT/FILL
- SPILLWAY

**KEYNOTES**

- 1 62' PRODUCTION TRUCK MOVEMENTS
- 2 LIMITS OF DISTURBANCE DURING CONSTRUCTION OR OGGA
- 3 TEMPORARY STAGING AREA
- 4 PARKING AREA
- 5 CREW QUARTERS
- 6 CREW MANAGER TEMPORARY HOUSE
- 7 DUMPSTER

WELLS			
1	BLUE JAY 3W-30-01	10	BLUE JAY 3W-30-10
2	BLUE JAY 3W-30-02	11	BLUE JAY 3W-30-11
3	BLUE JAY 3W-30-03	12	BLUE JAY 3W-30-12
4	BLUE JAY 3W-30-04	13	BLUE JAY 3W-30-13
5	BLUE JAY 3W-30-05	14	BLUE JAY 3W-30-14
6	BLUE JAY 3W-30-06	15	BLUE JAY 3W-30-15
7	BLUE JAY 3W-30-07	16	BLUE JAY 3W-30-16
8	BLUE JAY 3W-30-08	17	BLUE JAY 3W-30-17
9	BLUE JAY 3W-30-09	18	BLUE JAY 3W-30-18

**LAMP RYNEARSON**  
 4715 INNOVATION DR., STE. 100  
 FORT COLLINS, CO 80525  
 970.226.0342  
 LampRyNearson.com



FOR REVIEW  
 NOT RELEASED FOR CONSTRUCTION  
 PETER J CARLSON

BLUE JAY MULTI-WELL PAD  
 DRILLING AND PRODUCTION SITE PLAN  
 BLUE JAY MULTI-WELL PAD  
 NE/4, SE/4, SEC 3 T2S R66W

**811**  
 Know what's below.  
 Call before you dig.

REVISIONS	

DESIGNER / DRAFTER  
 JASON P. MCNEILL  
 DATE  
 10/03/2019  
 PROJECT NUMBER  
 0218002.07  
 BOOK AND PAGE

U:\Engineering\0218002.07 - Blue Jay\Drawings\CONSTRUCTION DRAWINGS\0218002.07-046 PLAN.dwg, 10/27/2019 2:00:33 PM, DILLON STARK, LAMP RYNEARSON



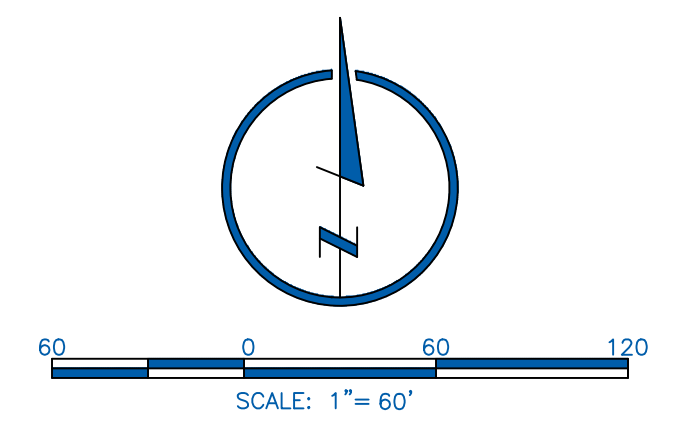
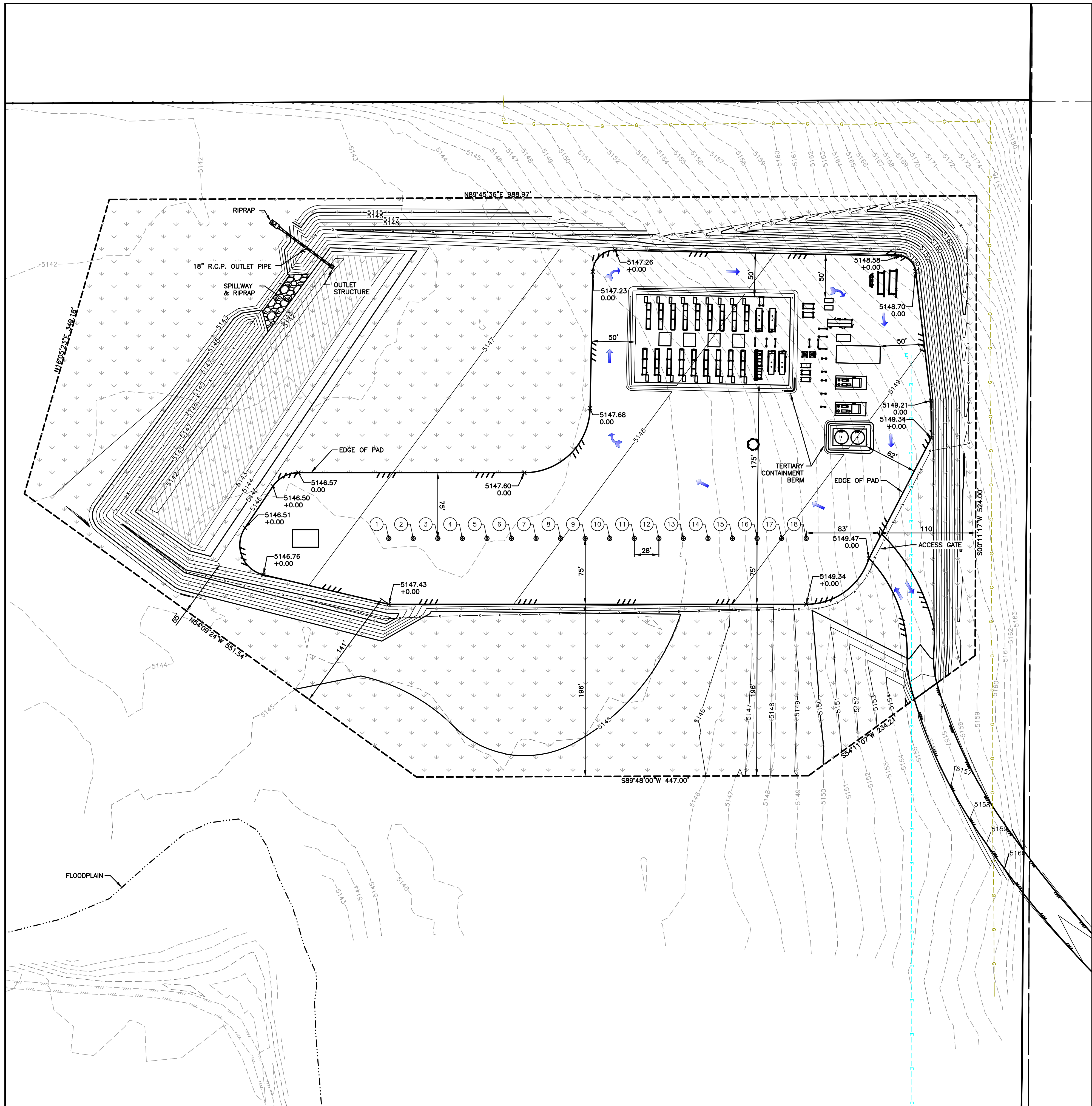

- LEGEND**
- EXISTING GAS LINE
  - EXISTING FENCE LINE
  - EXISTING RIGHT OF WAY
  - PROPOSED UNDERGROUND ELECTRIC LINE
  - EDGE OF GRAVEL
  - LIMITS OF OGOA
  - EXISTING ROAD
  - EXISTING CONTOUR LINE
  - PROPOSED CONTOUR LINE
  - DRAINAGE SWALE CENTER LINE
  - TRAFFIC FLOW
  - DETENTION POND
  - SPILLWAY
  - RECLAIMED AREA 9.38 AC
  - SPOT ELEVATION DEPTH OF CUT/FILL
  - 6' CEDAR FENCE

WELLS			
1	BLUE JAY 3W-30-01	10	BLUE JAY 3W-30-10
2	BLUE JAY 3W-30-02	11	BLUE JAY 3W-30-11
3	BLUE JAY 3W-30-03	12	BLUE JAY 3W-30-12
4	BLUE JAY 3W-30-04	13	BLUE JAY 3W-30-13
5	BLUE JAY 3W-30-05	14	BLUE JAY 3W-30-14
6	BLUE JAY 3W-30-06	15	BLUE JAY 3W-30-15
7	BLUE JAY 3W-30-07	16	BLUE JAY 3W-30-16
8	BLUE JAY 3W-30-08	17	BLUE JAY 3W-30-17
9	BLUE JAY 3W-30-09	18	BLUE JAY 3W-30-18

- KEYNOTES**
- 1) 62' PRODUCTION TRUCK MOVEMENTS
  - 2) LIMITS OF DISTURBANCE DURING CONSTRUCTION OR OGOA

**LAMP RYNEARSON**  
 4715 INNOVATION DR., STE. 100  
 FORT COLLINS, CO 80525  
 970.226.0342  
 LampRynearson.com



FOR REVIEW

NOT RELEASED FOR CONSTRUCTION  
 PETER J CARLSON

BLUE JAY MULTI-WELL PAD  
 INTERIM RECLAIMED SITE PLAN

BLUE JAY MULTI-WELL PAD  
 NE/4, SE/4, SEC 3 T2S R66W

**811**  
 Know what's below.  
 Call before you dig.

REVISIONS

NO.	DATE	DESCRIPTION

DESIGNER / DRAFTER  
 JASON P. MCNEILL  
 DATE  
 10/03/2019  
 PROJECT NUMBER  
 0218002.07  
 BOOK AND PAGE

U:\Engineering\0218002.07 - Blue Jay\Drawings\CONSTRUCTION DRAWINGS\0218002.07-04G PLAN.dwg, 10/27/2019 2:00:35 PM, DILLON STARK, LAMP RYNEARSON



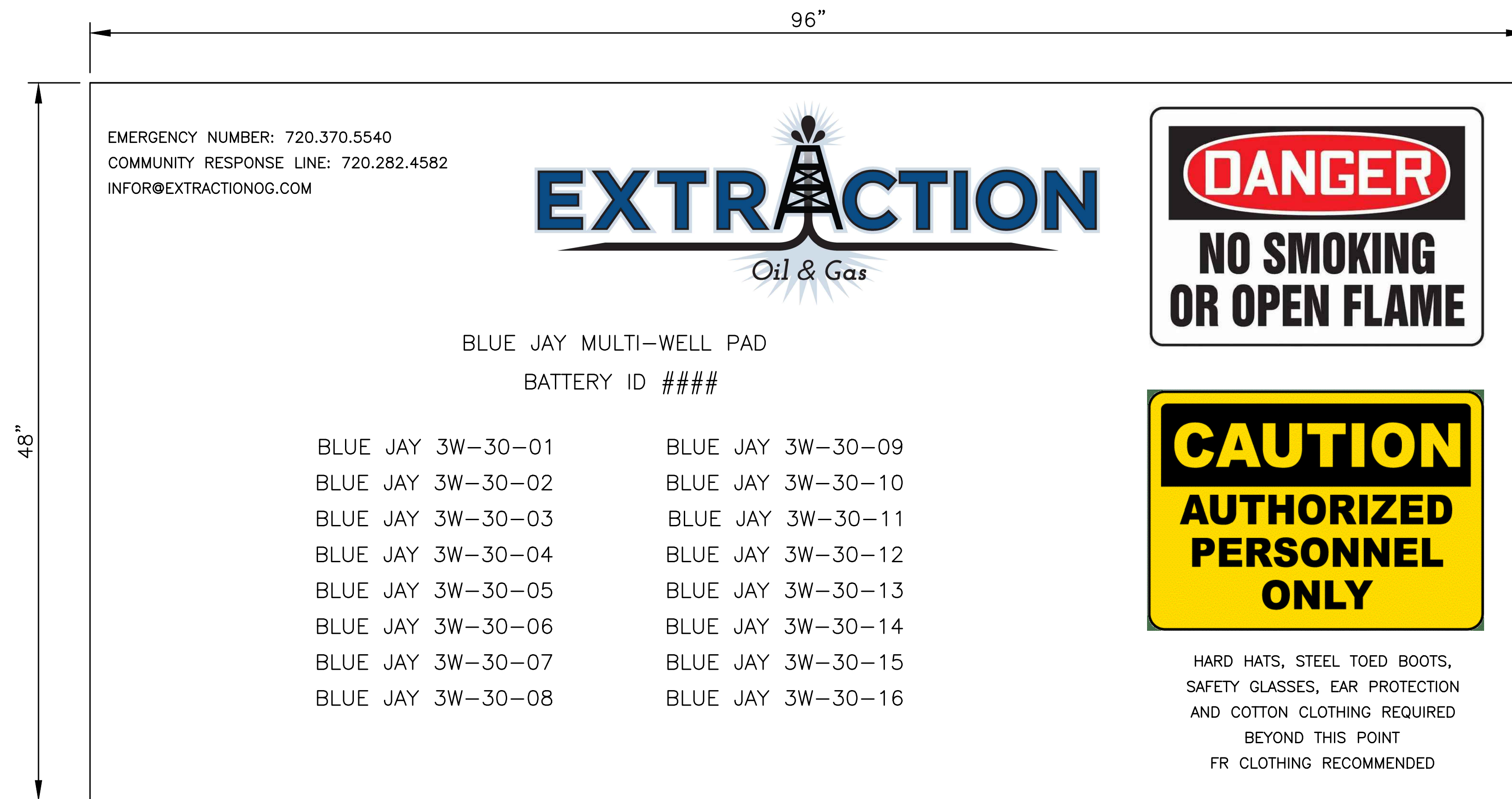

SIZE: 96" X 48"

MATERIAL: WHITE MAX METAL W/ UV LAMINATE AND

CONSTRUCTED ANGLE IRON FRAMES

LOCATION: PLACED AT FACILITY ENTRANCE

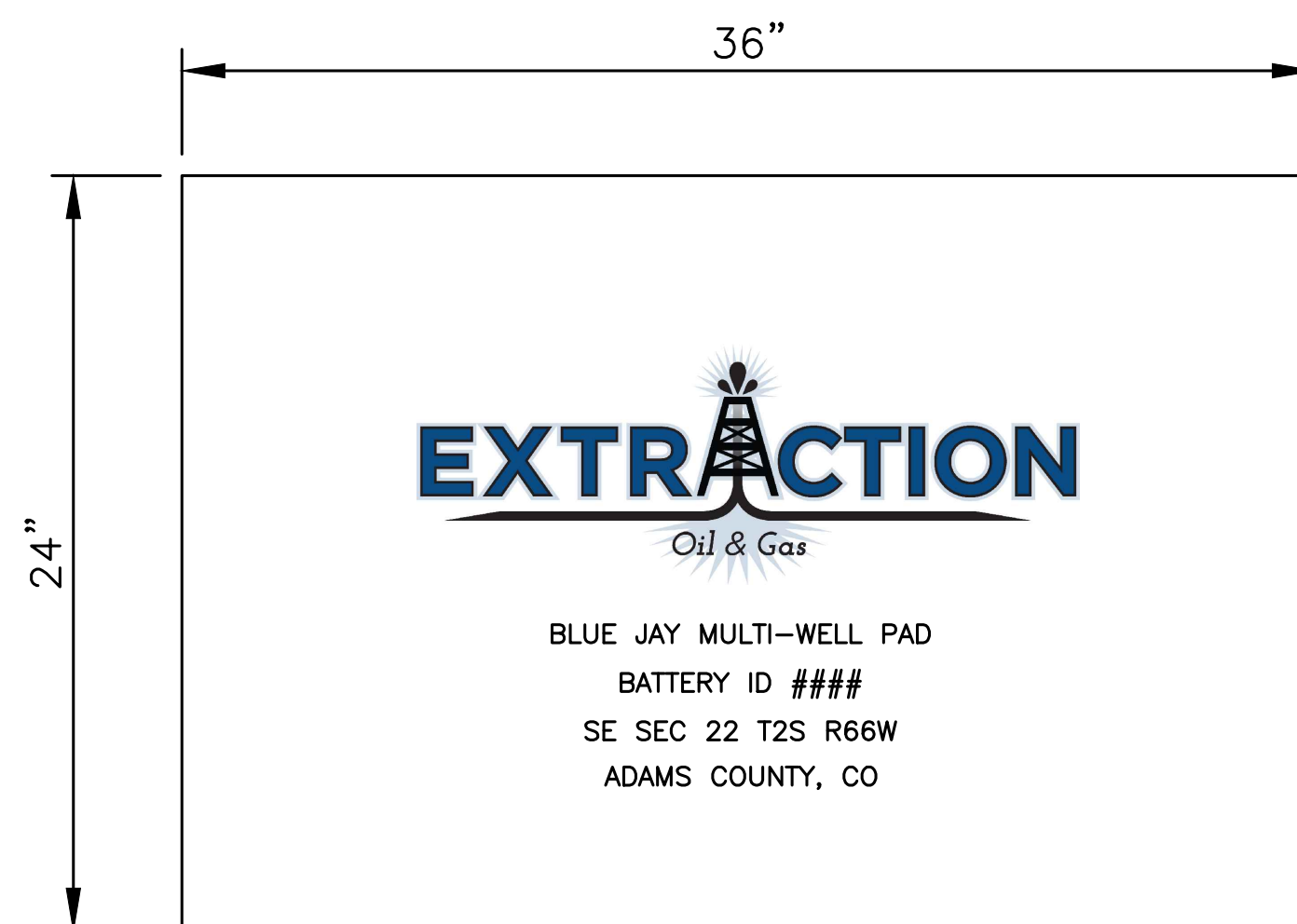

SIZE: 36" X 24"

MATERIAL: WHITE MAX METAL W/ UV LAMINATE AND

CONSTRUCTED ANGLE IRON FRAMES

LOCATION: PLACED AT EACH BATTERY

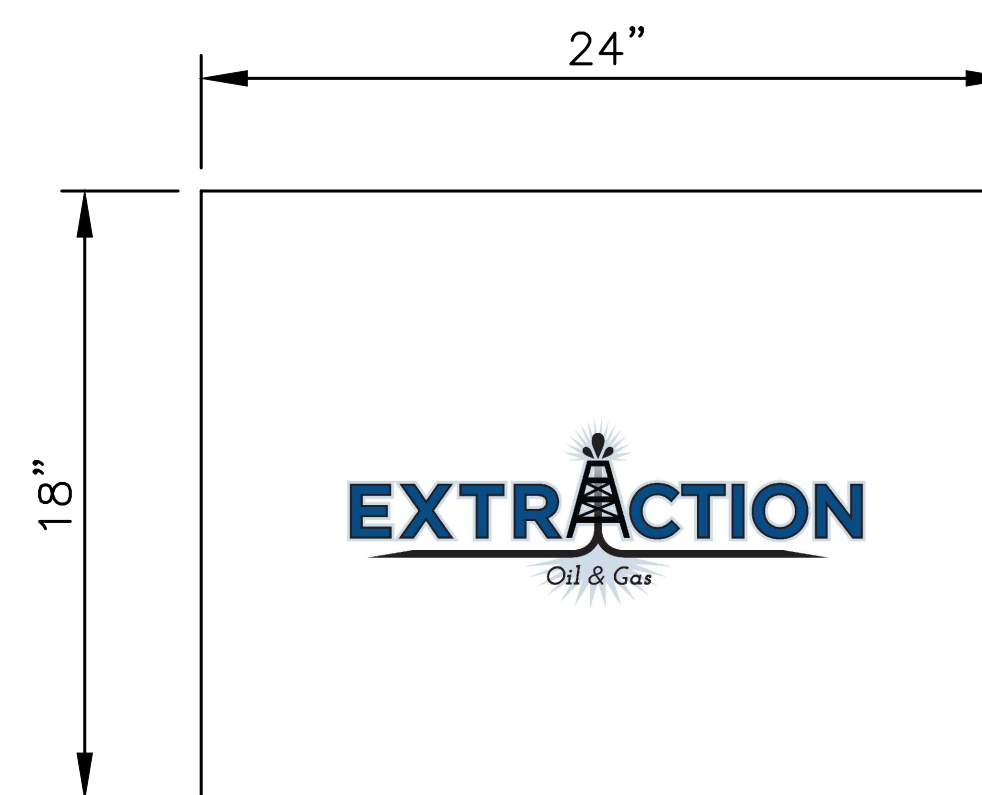

SIZE: 24" X 18"

MATERIAL: WHITE MAX METAL W/ UV LAMINATE AND

CONSTRUCTED ANGLE IRON FRAMES

LOCATION: PLACED AT EACH WELL HEAD

**SIGNAGE PLAN**  
NOT TO SCALE

**LAMP RYNEARSON**  
4715 INNOVATION DR., STE. 100  
FORT COLLINS, CO 80525  
970.226.0342  
LampRynearson.com



FOR REVIEW

NOT RELEASED FOR CONSTRUCTION  
PETER J CARLSON

BLUE JAY MULTI-WELL PAD  
DETAILS

BLUE JAY MULTI-WELL PAD  
NE/4, SE/4, SEC 3 T2S R66W

**811** Know what's below.  
Call before you dig.

REVISIONS

DESIGNER / DRAFTER  
JASON P. MCNEILL  
DATE  
10/03/2019  
PROJECT NUMBER  
0218002.07  
BOOK AND PAGE

L:\Engineering\0218002.07 - Blue Jay\DRAWINGS\CONSTRUCTION - DRAWINGS\0218002.07-ESCP-DETAILS.dwg, 10/7/2019 2:00:43 PM, DILLON STARK, LAMP RYNEARSON



FOR REVIEW

NOT RELEASED FOR CONSTRUCTION  
PETER J CARLSON

**BLUE JAY MULTI-WELL PAD  
LANDSCAPING PLAN**

**BLUE JAY MULTI-WELL PAD  
NE/4, SE/4, SEC 3 T2S R66W**

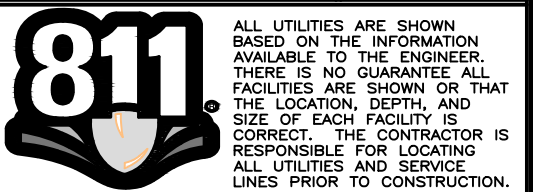

Know what's below.  
Call before you dig.

REVISIONS

DESIGNER / DRAFTER  
JASON P. MCNEILL  
DATE  
10/03/2019  
PROJECT NUMBER  
0218002.07  
BOOK AND PAGE

SHEET

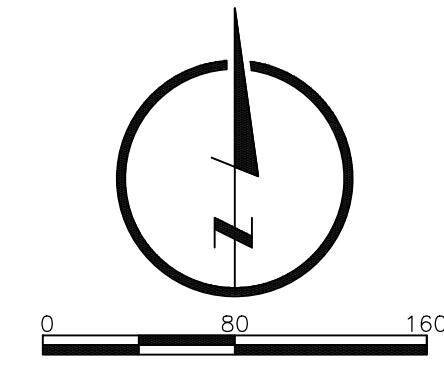

**LEGEND**

- X X X X X X X X --- EXISTING FENCE LINE
- E E E E E E E E --- PROPOSED UNDERGROUND ELECTRIC LINE
- G G G G G G G G --- EXISTING GAS LINE
- / / / / / / / / --- EDGE OF GRAVEL
- - - - - - - - - --- LIMITS OF DISTURBANCE (DA)
- - - - - - - - - --- EXISTING ROAD
- - - - - - - - - --- FLOOD PLAIN BOUNDARY
- - - - - - - - - --- BRIGHTON 1-189 PROTECTED WATER BOUNDARY
- 1100 --- EXISTING CONTOUR LINE
- X X X X X X X X --- 6' CEDAR FENCE

**PLANT SCHEDULE**

TREES	CODE	COMMON NAME	BOTANICAL NAME	PLANTING SIZE	METHOD	HEIGHT	WIDTH	QTY
	CO3	COMMON HACKBERRY	CELTIS OCCIDENTALIS	2" CAL.	B&B	40-50 FT	40-50 FT	7
	GK2	KENTUCKY COFFEE TREE	GYMNOCLADUS BOICA	2" CAL.	B&B	30-40 FT	40-50 FT	7
	MA	ADAMS CRABAPPLE	MALLUS X 'ADAMS'	2" CAL.	B&B	15-20 FT	15-20 FT	8
	JE	ROCKY MOUNTAIN JUNIPER	JUNIPERUS SCOPULORUM	6' - 7' HT.	B&B	20-30 FT	15-20 FT	12
	PP2	PONDEROSA PINE	PINUS PONDEROSA	6' - 7' HT.	B&B	60-70FT	20-30FT	14
	PE4	PINYON PINE	PINUS CEMBOIDES EDULIS	6' - 7' HT.	B&B	60-70 FT	20-30 FT	9
COLORADO								
GROUND COVERS	CODE	COMMON NAME	BOTANICAL NAME	PLANTING SIZE	METHOD	HEIGHT	WIDTH	QTY
	FP	APACHE PLUME	FALLUGIA PARADOXA	5 GAL.	CONT.	3-5 FT	5-6 FT	31
	JS	ARMSTRONG JUNIPER	JUNIPERUS CHINENSIS 'ARMSTRONG'	5 GAL.	CONT.	3-4 FT	4-6 FT	16
	PM	MUGO PINE	PINUS MUGO	5 GAL.	CONT.	6-8 FT	6-8 FT	15
	RC	WESTERN SMOOTH SUMAC	RHUS LANCEOLATA	5 GAL.	CONT.	2-3 FT	2-3 FT	30
	NA SE	(30%)WESTERN WHEATGRASS	PASCOPYRUM SMITHII		SEED			346,638 SF
		(30%)INDIAN RICEGRASS	ACHANTHERUM HYMENOIDES					
		(20%)SLENDER WHEATGRASS	ELYMUS TRACHYCALIUS					
		(20%)SAND DROPSSEED	SPOROBOLUS CRYPTANRUS					

**LANDSCAPE CODE REVIEW**

	REQUIRED	PROVIDED
A. MINIMUM DEPTH LANDSCAPE BUFFER ZONES	15'	30'
...REQUIRED TREES	5 PER 100 LINEAR FEET OF REQUIRED LANDSCAPE AREA: (1,144 LF / 100) X 5 = 57 TREES	PROPOSED TREES = 57
...REQUIRED SHRUBS	8 PER 100 LINEAR FEET OF REQUIRED LANDSCAPE AREA: (1,144 LF / 100) X 8 = 92 SHRUBS	PROPOSED SHRUBS = 92

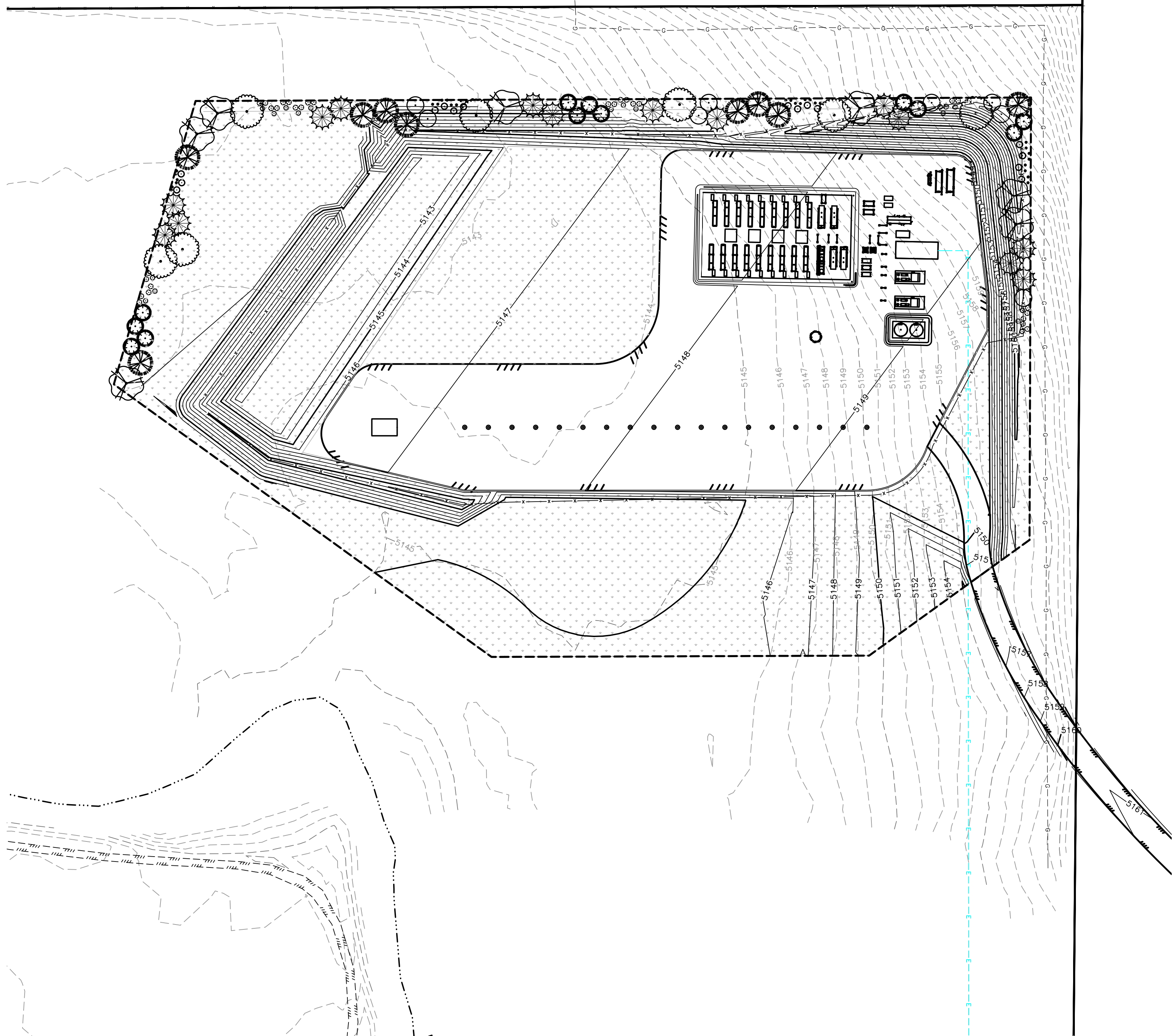

**1 LANDSCAPE PLAN**

L:\Engineering\0218002.07 - Blue Jay\Drawings\CONSTRUCTION DRAWINGS\0218002.07-LS-01.dwg, 10/03/2019 2:01:12 PM, JILLIAN STARCH, LAMP RYNEARSON



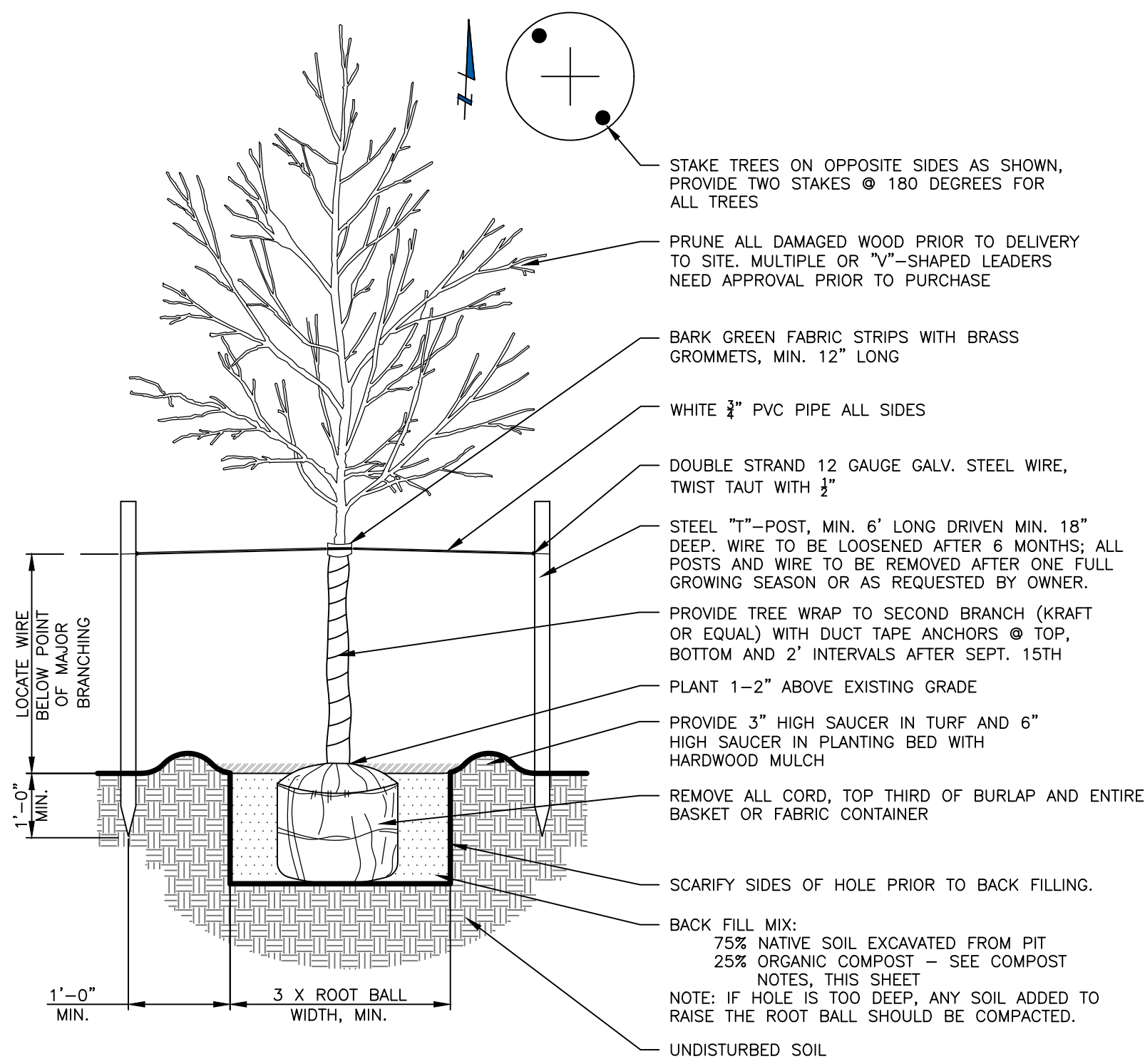

**1 DECIDUOUS TREE PLANTING & STAKING DETAIL**  
SCALE: NOT TO SCALE

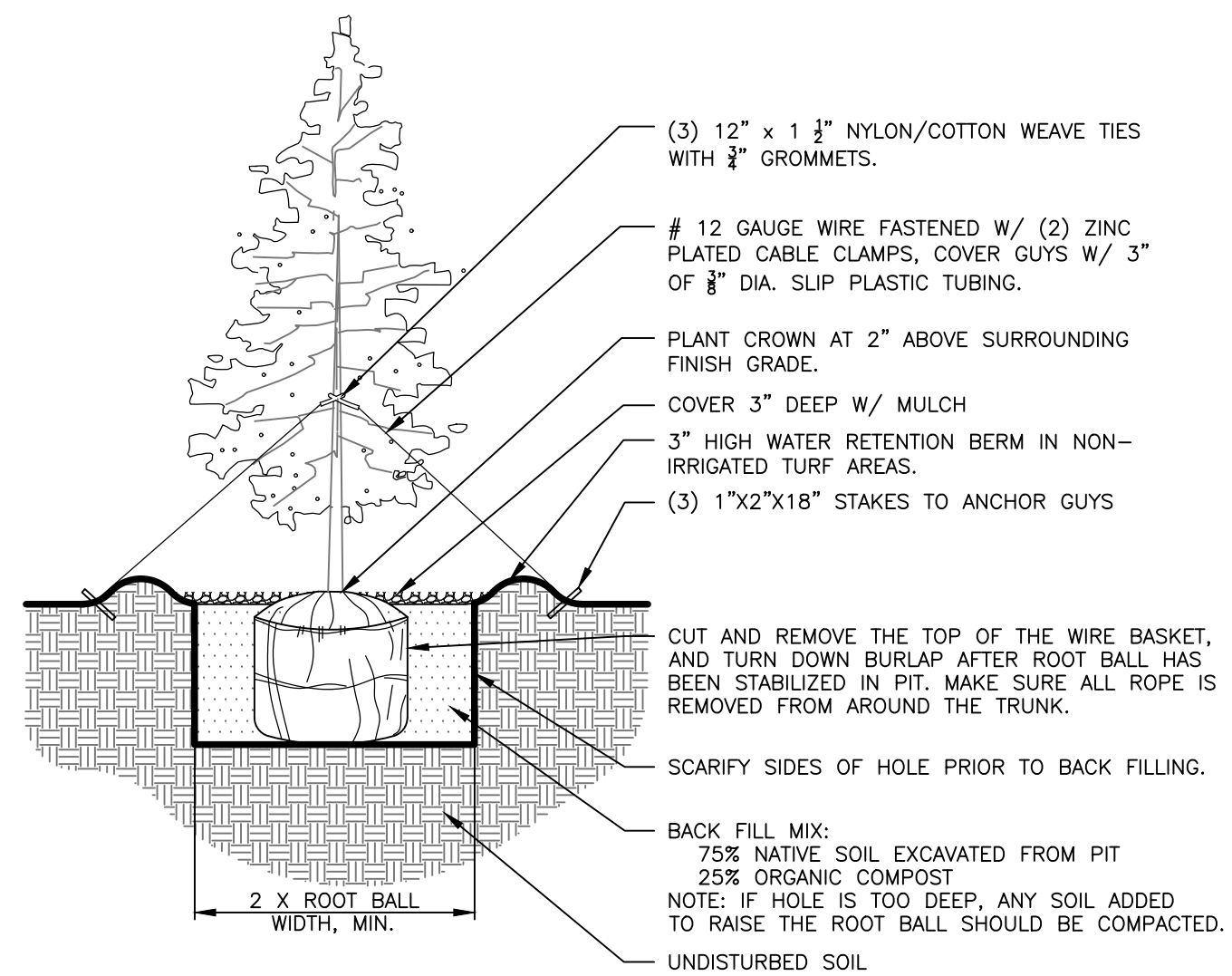

**2 EVERGREEN TREE PLANTING & STAKING DETAIL**  
SCALE: NOT TO SCALE

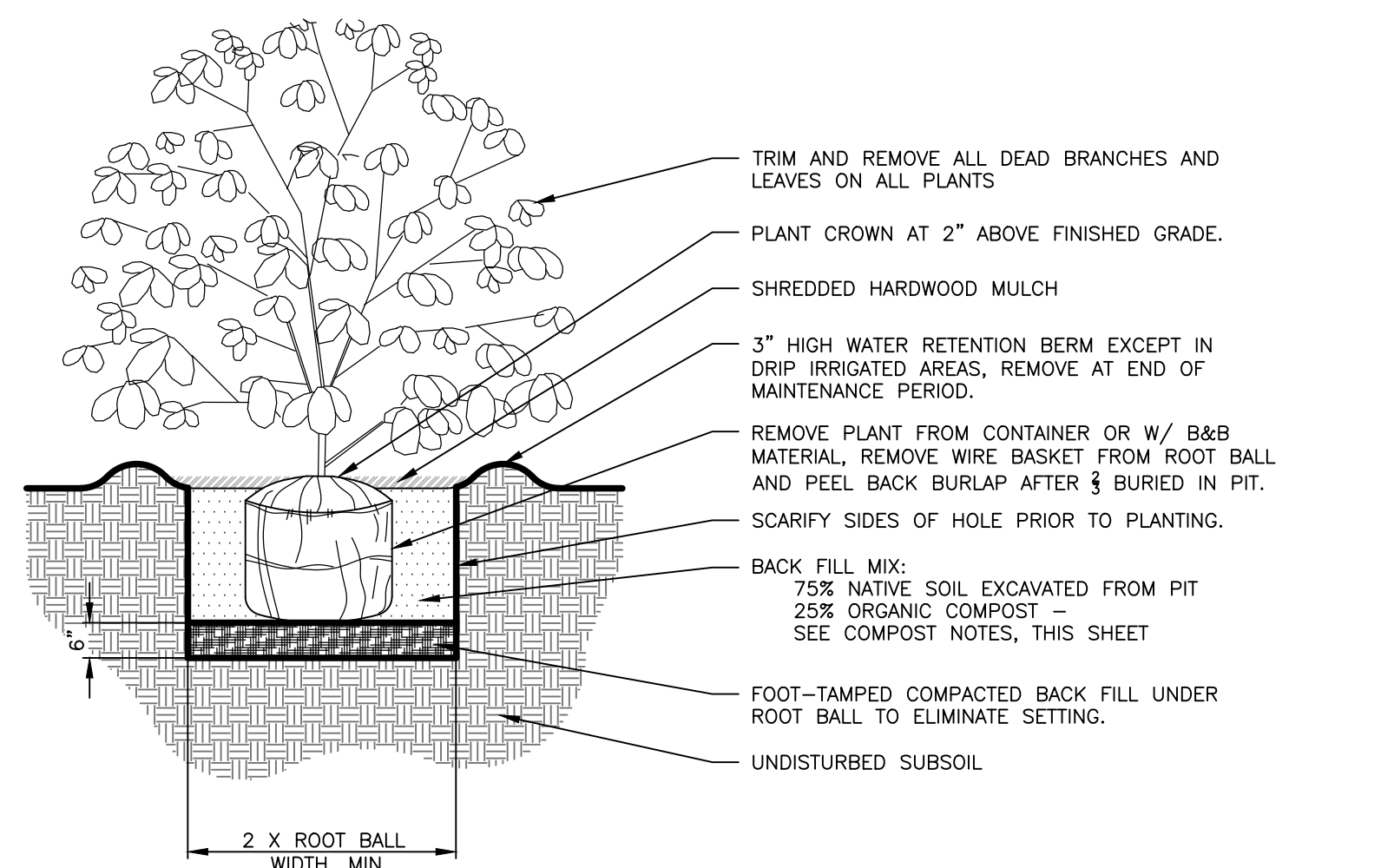

**3 TYPICAL SHRUB PLANTING DETAIL**  
SCALE: NOT TO SCALE

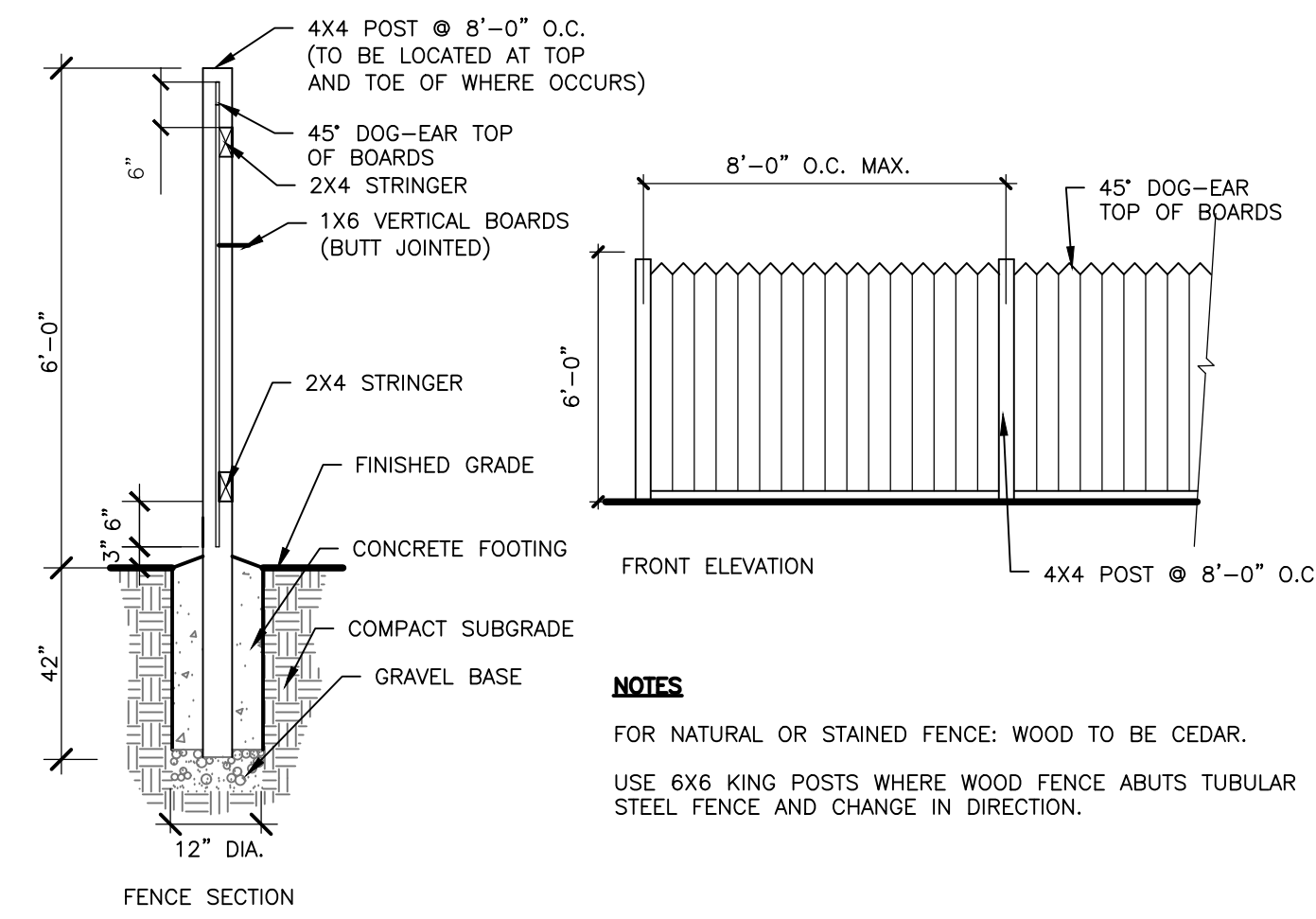

**5 CEDAR FENCE DETAIL**  
SCALE: NOT TO SCALE

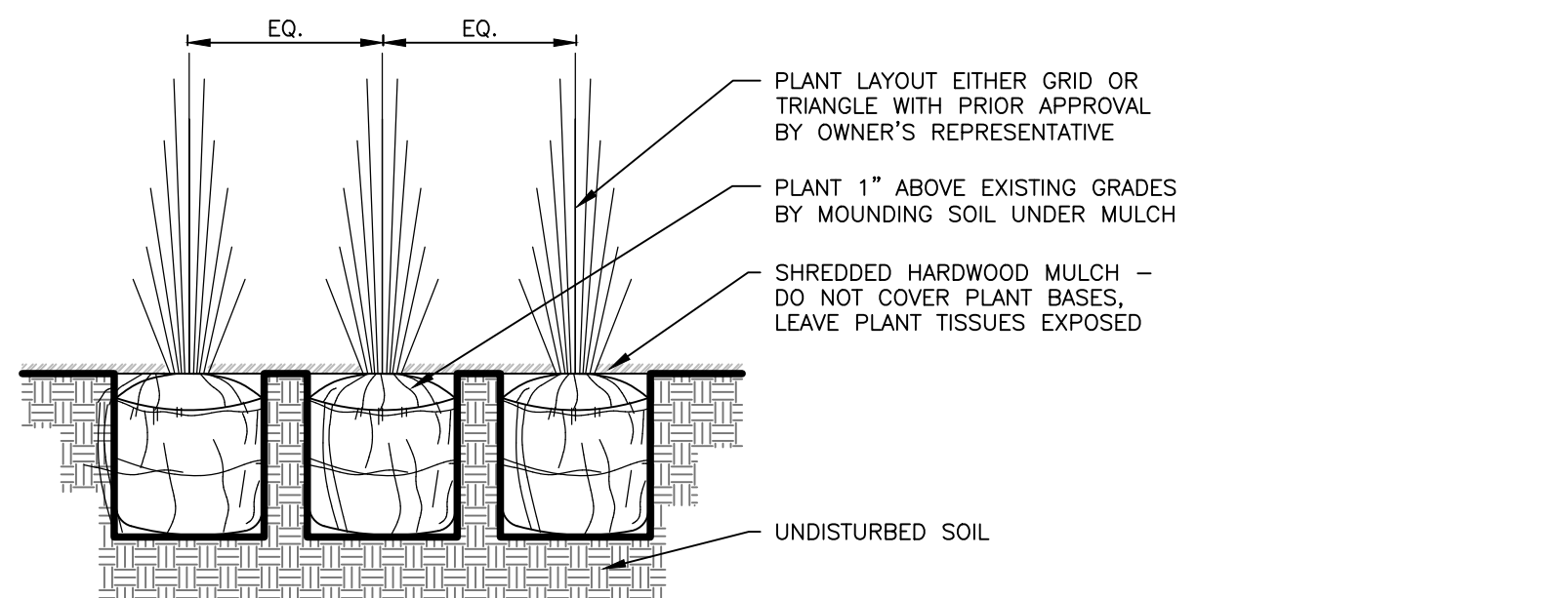

**4 TYPICAL PERENNIAL AND ORNAMENTAL GRASS PLANTING DETAIL**  
SCALE: NOT TO SCALE

**COMPOST**

USE A COMPOST MEETING THE REQUIREMENTS OF THIS SECTION. MATERIAL SHALL BE WELL COMPOSTED, FREE OF WEED SEEDS AND STABILIZED WITH REGARD TO OXYGEN CONSUMPTION AND CARBON DIOXIDE GENERATION. COMPOST SHALL HAVE A MOISTURE CONTENT THAT HAS NO VISIBLE FREE WATER OR DUST PRODUCED WHEN HANDLING THE MATERIAL. ONE HUNDRED PERCENT OF THE MATERIAL MUST PASS THROUGH A HALF INCH SCREEN. MANUFACTURED INERT MATERIAL SHALL BE LESS THAN 1.0% BY WEIGHT.

	MIN.	MAX.
ORGANIC MATTER CONTENT	35%	65%
C/N RATIO	-	25:1
PH	6.0	8.0
BULK DENSITY (LBS/CF)	40	50

**WARRANTY**

THE CONTRACTOR SHALL WARRANTY PLANT MATERIALS FOR A PERIOD OF TWO (2) YEARS FROM THE DATE OF SUBSTANTIAL COMPLETION, AGAINST DEFECTS INCLUDING DEATH AND UNSATISFACTORY GROWTH, EXCEPT FOR DEFECTS RESULTING FROM ABUSE OR DAMAGE BY OTHERS, OR UNUSUAL PHENOMENA OR INCIDENTS WHICH ARE BEYOND THE CONTROL OF THE CONTRACTOR. WARRANTY COVERS A MAXIMUM OF ONE REPLACEMENT PER ITEM.

**PLANTING NOTES**

- INSTALL ALL TREES A MINIMUM OF FOUR (4) FEET FROM BACK OF CURB, EDGE OF WALL OR PAVING.
- PLANT NAMES ARE ABBREVIATED ON THE DRAWINGS. SEE PLANT LIST FOR KEY AND CLASSIFICATION.
- PLACE A 3" DEPTH LAYER OF TRIPLE SHREDDED HARDWOOD MULCH ON ALL PLANTING AREAS EXCEPT LAWN. SUBMIT SAMPLE TO LANDSCAPE ARCHITECT FOR APPROVAL.
- LOCATION OF ALL PLANTING IS DIAGRAMMATIC. DO NOT WILLFULLY LOCATE PLANTINGS WHERE CONFLICTS EXIST WITH UTILITIES OR THE BUILDING.
- EXISTING AND IMPORTED SOIL FOR PLANTING AREAS SHALL BE FREE FROM CHEMICALS, CONSTRUCTION DEBRIS AND TRASH, ROCKS AND OTHER MATERIAL LARGER THAN ONE INCH IN DIAMETER.
- PLANT QUANTITIES ARE SHOWN FOR THE CONVENIENCE TO THE CONTRACTOR. IF THERE ARE DISCREPANCIES BETWEEN THE PLAN AND NOTES, THE PLANS SHALL GOVERN.
- ALL PLANTED AREAS TO BE AMENDED PER AN AGRICULTURAL/SOIL SUITABILITY TEST, PAID FOR BY OWNER. FOR BID PURPOSES CONTRACTOR SHALL ESTIMATE SPREADING SOIL AMENDMENT AT THE RATE OF 6 CUBIC YARDS PER 1,000 SQUARE FEET. TILL INTO THE TOP OF SOIL TO A MINIMUM DEPTH OF 6". RAKE TO A SMOOTH, EVEN SURFACE PER THE GRADING PLANS.

**MAINTENANCE STANDARDS**

- ALL LANDSCAPING AND REQUIRED BUFFERING SHALL BE CONTINUALLY MAINTAINED INCLUDING IRRIGATION IF APPLICABLE (NO IRRIGATION SYSTEM WILL BE PROVIDED AT THIS LOCATION) WEEDING, PRUNING, AND REPLACING IN A SUBSTANTIALLY SIMILAR MANNER AS ORIGINALLY APPROVED. THE FOLLOWING SURVIVAL STANDARDS SHALL APPLY TO ALL LANDSCAPING AND REQUIRED BUFFERING:
- LIVING GROUND COVERS: LIVING GROUND COVERS MUST BE FIFTY PERCENT (50%) ESTABLISHED AFTER THE FIRST GROWING SEASON, AND NINETY PERCENT (90%) ESTABLISHED THEREAFTER.
  - NON-LIVING GROUND COVERS: NON-LIVING GROUND COVERS, SUCH AS ROCK OR MULCH MUST BE ONE HUNDRED PERCENT (100%) INTACT AFTER ONE (1) YEAR AND EIGHTY PERCENT (80%) INTACT THEREAFTER.
  - TREES AND SHRUBS: TREES AND SHRUBS MUST HAVE A ONE HUNDRED PERCENT (100%) SURVIVAL RATE AFTER ONE (1) YEAR AND A NINETY PERCENT (90%) SURVIVAL RATE THEREAFTER.

**SEED MIX NOTES**

- SEED SHALL BE FURNISHED IN BAGS OR CONTAINERS CLEARLY LABELED TO SHOW THE NAME AND ADDRESS OF THE SUPPLIER, THE SEED NAME, THE LOT NUMBER, NET WEIGHT, THE PERCENT OF WEED SEED CONTENT AND THE GUARANTEED PERCENTAGE OF PURITY AND GERMINATION.
- THE CONTRACTOR SHALL SUBMIT TO THE PROJECT REPRESENTATIVE A SIGNED STATEMENT CERTIFYING THAT THE SEED FURNISHED IS FROM A LOT THAT HAS BEEN TESTED WITHIN SIX MONTHS PRIOR TO THE DATE OF DELIVERY. SEED WHICH HAS BECOME WET, MOLDY OR OTHERWISE DAMAGED IN TRANSIT OR IN STORAGE WILL NOT BE ACCEPTABLE.
- SEED AND SEED LABELS SHALL CONFORM TO ALL CURRENT STATE AND FEDERAL REGULATIONS AND WILL BE SUBJECT TO THE TESTING PROVISIONS OF THE ASSOCIATION OF OFFICIAL SEED ANALYSIS.
- COMPUTATIONS FOR QUANTITY OF SEED REQUIRED ARE BASED ON THE PERCENT OF PURITY AND PERCENT OF GERMINATION: POUNDS OF SEED X PURITY X GERMINATION = POUNDS OF PURE LIVE SEED (PLS).
- SITE PREPARATION FOR BAREGROUND SEEDING:
  - CONDUCT A SOIL TEST, PER ACRE, TO DETERMINE ANY NEEDED SOIL AMENDMENTS. IDEAL SOIL PH IS BETWEEN 6.0 AND 7.0.
  - REMOVE ALL EXISTING VEGETATION. SPRAY SEED AREA WITH NON-SELECTIVE HERBICIDE, REMOVE DEAD VEGETATION AND LARGE DEBRIS.
  - ADD SOIL AMENDMENTS AS NECESSARY TO ADJUST SOIL PH LEVELS AND TILL SOIL TO A 4" - 6" DEPTH. PULVERIZE AND LIGHTLY ROLL SOIL.
  - APPLY 1 LB OF PHOSPHOROUS(P) (2.27 LBS P205)/1000 SQ.FT. TO SOIL SURFACE.
- SEEDING METHODS, BASED ON THE SLOPE AND SOIL AT SITE. USE BROADCAST, DROP, SILT OR DRILL SEEDING METHODS WHERE EROSION IS NOT A CONCERN.
  - DRILL SEEDING = 25LBS PER ACRE AND BROADCAST SEEDING = 37.5 LBS PER ACRE
  - SEED SHOULD BE PLANTED 1/25 TO 25 INCHES BELOW SOIL SURFACE, IN TWO DIRECTIONS PUTTING 1/2 OF THE SEED DOWN EACH DIRECTION. SEEDED AREAS SHOULD BE GENTLY ROLLED OR RAKED TO ENSURE GOOD SOIL TO SEED CONTACT.
- WATERING REQUIREMENTS:
  - WATER TO FIELD CAPACITY IMMEDIATELY AFTER SEEDING.
  - WEEK 1 - 3 AFTER SEEDING SOIL SHALL BE MOIST TO 1 INCH DEPTH.
  - WEEKS 4-6 AFTER SEEDING AREA SHALL BE WATERED 3-4 TIMES PER WEEK.
  - AFTER 6 WEEKS GRASS SHALL ONLY NEED WATER WHEN IT BEGINS TO SHOW DROUGHT STRESS.
- FERTILIZE SEEDED AREA ONCE FOR THE FIRST TWO MONTHS WITH .5 LBS OF N/1000 SQ.FT. AFTER SEEDING.
- MOW WHEN THE GRASS IS ONE INCH LONGER THAN DESIRED HEIGHT. DO NOT REMOVE MORE THAN 1/3 OF GRASS BLADE.

**GENERAL NOTES**

- CONTRACTOR TO VERIFY LOCATION OF ALL PROPOSED AND EXISTING VAULTS, ELECTRICAL DUCT BANKS, MANHOLES, CONDUIT AND PIPING, DRAINAGE STRUCTURES AND OTHER UTILITIES PRIOR TO COMMENCING WORK.
- CONTRACTOR SHALL NOT WILLFULLY INSTALL ANY PROPOSED LANDSCAPE IMPROVEMENTS WHEN CONFLICTS EXIST BETWEEN LANDSCAPE IMPROVEMENTS AND EXISTING OR PROPOSED UTILITIES OR SITE FEATURES SUCH AS WALKS, ROADS, BUILDINGS OR EXISTING TREES TO REMAIN.
- VERIFY LOCATION OF ALL BUILDINGS, WALLS, ROADS AND CURBS AFFECTING LANDSCAPE SCOPE OF WORK WITH ARCHITECTS AND CONTRACTOR ENGINEER'S DRAWINGS.
- REFERENCE TO NORTH REFERS TO TRUE NORTH, REFERENCE TO SCALE IS FOR FULL-SIZED DRAWINGS ONLY. DO NOT SCALE FROM REDUCED DRAWINGS.
- DIMENSIONS TAKE PRECEDENCE OVER SCALES SHOWN ON DRAWINGS.
- WHERE NOT SHOWN ON THE PLANTING PLANS, SEE CONTRACTOR ENGINEER'S AND ARCHITECT'S DRAWINGS FOR BUILDING FOUNDATIONS SETBACKS, BOUNDARIES, SUBSURFACE AND ABOVE GRADE UTILITIES.

**TREE PLANTING NOTES**

- PROVIDE MATCHING SIZES AND FORMS FOR EACH SPECIES OF TREE INSTALLED ON GRID OR SPACED EQUALLY IN ROWS AS SHOWN ON DRAWINGS. ALIGN TREES ACROSS WALKS. ADJUST SPACING AS NECESSARY, SUBJECT TO REVIEW BY THE LANDSCAPE ARCHITECT.
- FORM 30 INCH WATERING BASIN AROUND ALL TREES NOT INSTALLED IN LAWN OR PAVED AREAS. FILL BASIN WITH MULCH PER TREE PLANTING DETAIL, THIS SHEET.
- REPLACEMENT OF UNACCEPTABLE PLANT MATERIAL: THE CONTRACTOR'S RESPONSIBILITY FOR REPLACEMENT OF UNACCEPTABLE PLANT MATERIAL SHALL EXTEND FOR TWO (2) YEARS AFTER ALL PLANT MATERIAL IS ACCEPTED BY THE ENGINEER.
- SUBMITTALS: THE CONTRACTOR SHALL PLANT TREES THAT HAVE BEEN GROWN IN USDA COLD HARDINESS ZONE 5 OR NORTHERLY. A CERTIFICATE OF ORIGIN MUST BE SUBMITTED FOR EACH SPECIES OF TREE THAT IS TO BE PLANTED. THE CONTRACTOR SHALL ALSO SUBMIT HIS LANDSCAPING PLAN PRIOR TO STARTING WORK IF IT VARIES FROM THE BID PLAN.
- MULCH: THE CONTRACTOR SHALL PLACE 3 CUBIC FEET OF TRIPLE SHREDDED HARDWOOD MULCH IN A 3-FOOT DIAMETER RING AT THE BASE OF EACH TREE THAT IS PLANTED. ANY MULCH PLACED IN EXCESS OF THE REQUIREMENTS SHALL BE AT THE CONTRACTOR'S EXPENSE.
- IN LIEU OF IRRIGATION, ALL NEWLY PLANTED TREES TO RECEIVE "TREEGATOR SLOW RELEASE WATERING BAG" BY SPECTRUM PRODUCTS, INC. OR OWNER APPROVED EQUAL. CONTRACTOR SHALL INSTALL AND FILL WATERING BAGS PER MANUFACTURERS SPECIFICATIONS.

FOR REVIEW

NOT RELEASED FOR CONSTRUCTION

PETER J CARLSON

BLUE JAY MULTI-WELL PAD  
LANDSCAPING NOTES

BLUE JAY MULTI-WELL PAD  
NE/4, SE/4, SEC 3 T2S R66W

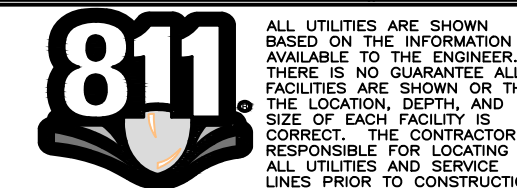

Know what's below.  
Call before you dig.

**REVISIONS**

NO.	DATE	DESCRIPTION

**DESIGNER / DRAFTER**

JASON P. MCNEILL  
DATE  
10/03/2019  
PROJECT NUMBER  
0218002.07  
BOOK AND PAGE

**SHEET**

U:\Engineering\0218002.07 - Blue Jay\Drawings\CONSTRUCTION DRAWINGS\0218002.07-LS-01.dwg - 10/02/2019 2:01:18 PM - LILLIAN STARCH, LAMP RYNEARSON